

CMOS IC Application Note

S-8204A Series Connection Examples Rev.1.3_00

The S-8204A Series is a protection IC for 3-series or 4-series cell rechargeable lithium-ion battery, and includes a voltage detection circuit with high accuracy and a delay circuit. By using cascade connection, it is also possible to protect 6-series or more cells rechargeable lithium-ion battery pack.

In case of protecting 5-series cell lithium ion battery packs, contact out sales office.

This application note is guideline on the typical connection examples when using the S-8204A Series for applications, and contains the parts list.

See the datasheet for details and spec of this IC.

It is possible to configure the following applications with the S-8204A Series.

- A protection circuit with series multi-cell; 3 cells or more

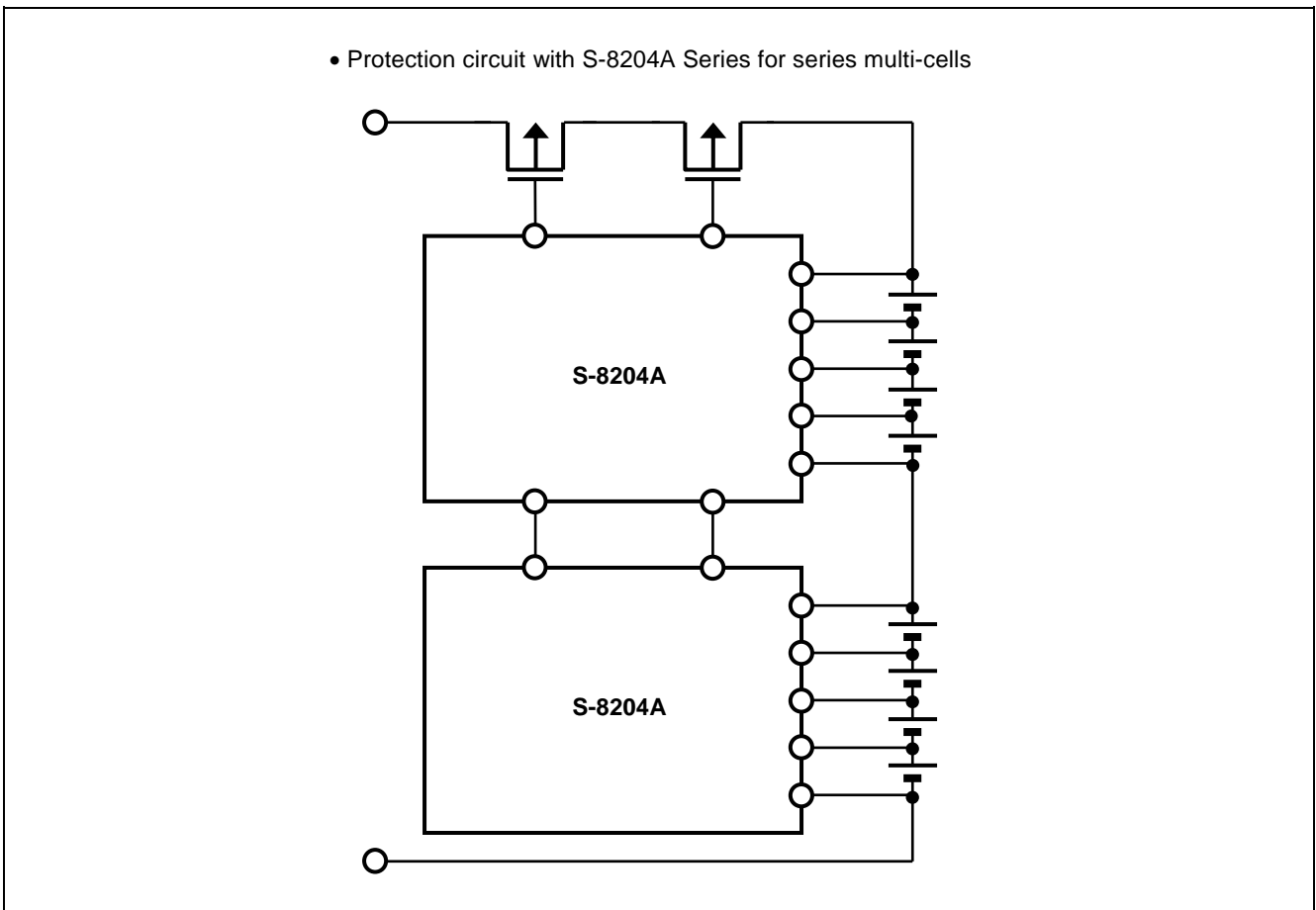

Contents

1. Protection circuit with S-8204A Series for multi-cells (Cascade connection)	3
1. 1 Protection circuit with 6-series cell (with discharge overcurrent protect function)	3
1. 2 Protection circuit with 6-series cell (with discharge overcurrent protect function and automatic recovery function)	4
1. 3 Protection circuit with 6-series cell (with discharge overcurrent protect function and charge overcurrent protect function)	5
1. 4 Protection circuit with 6-series cell (with discharge overcurrent protect function, automatic recovery function and charge overcurrent protect function)	6
1. 5 Protection circuit with 7-series cell (with discharge overcurrent protect function)	7
1. 6 Protection circuit with 7-series cell (with discharge overcurrent protect function and automatic recovery function)	8
1. 7 Protection circuit with 7-series cell (with discharge overcurrent protect function and charge overcurrent protect function)	9
1. 8 Protection circuit with 7-series cell (with discharge overcurrent protect function, automatic recovery function and charge overcurrent protect function)	10
1. 9 Protection circuit with 8-series cell (with discharge overcurrent protect function)	11
1. 10 Protection circuit with 8-series cell (with discharge overcurrent protect function and automatic recovery function)	12
1. 11 Protection circuit with 8-series cell (with discharge overcurrent protect function and charge overcurrent protect function)	13
1. 12 Protection circuit with 8-series cell (with discharge overcurrent protect function, automatic recovery function and charge overcurrent protect function)	14
1. 13 External parts list	15
2. Precaution	17
3. Related source	17

1. Protection circuit with S-8204A Series for multi-cells (Cascade connection)

1.1 Protection circuit with 6-series cell (with discharge overcurrent protect function)

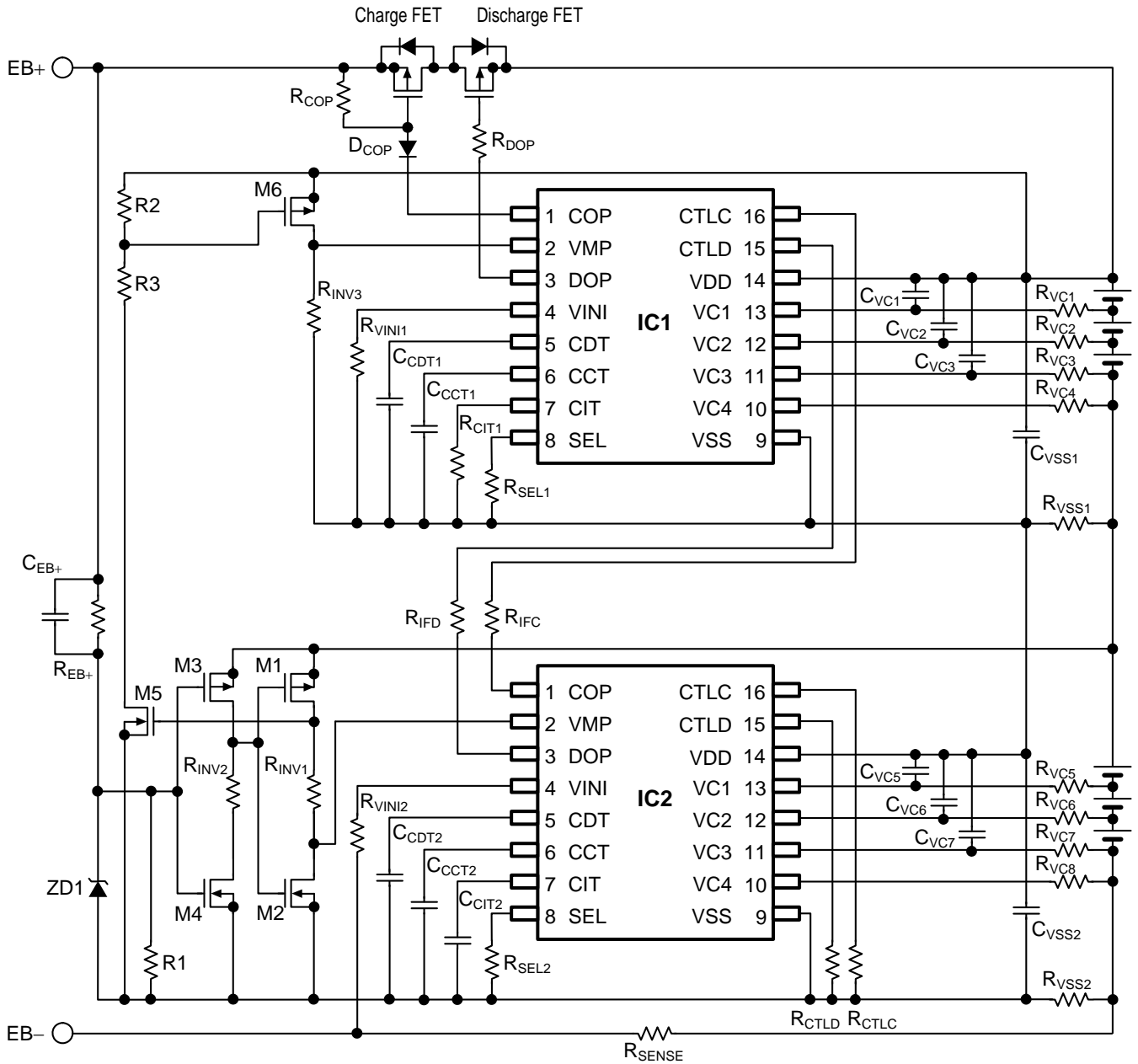

Remark Refer to "1.13 External parts list" for constants of external parts.

Figure 1

Caution 1. The above connection example may be changed without notice.

2. It has not been confirmed whether the operation is normal or not in circuits other than the above example of connection. The example of connection shown above will not guarantee successful operation.

1.2 Protection circuit with 6-series cell
(with discharge overcurrent protect function and automatic recovery function)

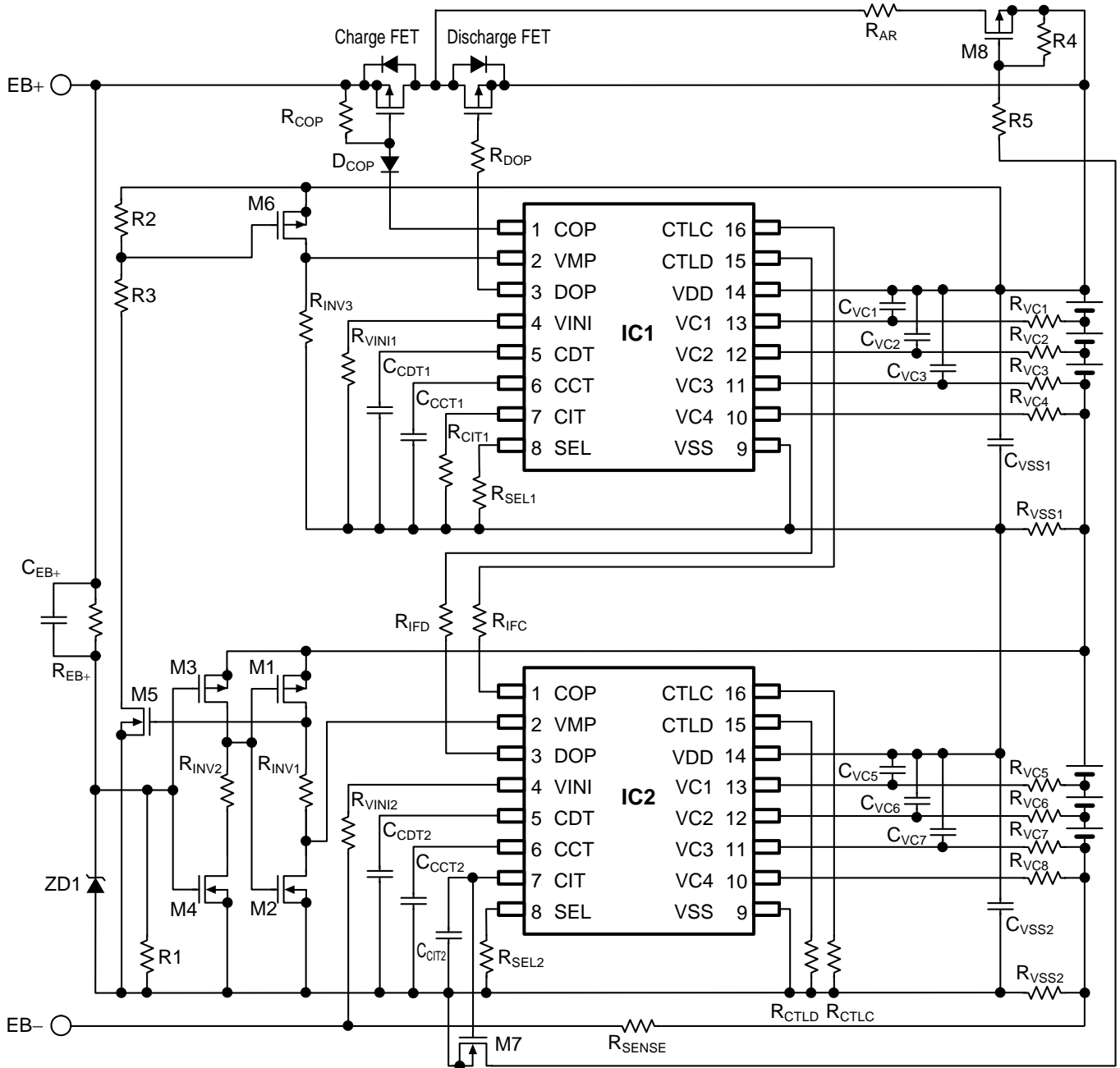

Remark Refer to "1.13 External parts list" for constants of external parts.

Figure 2

- Caution 1. The above connection example may be changed without notice.
2. It has not been confirmed whether the operation is normal or not in circuits other than the above example of connection. The example of connection shown above will not guarantee successful operation.

**1.3 Protection circuit with 6-series cell
(with discharge overcurrent protect function and charge overcurrent protect function)**

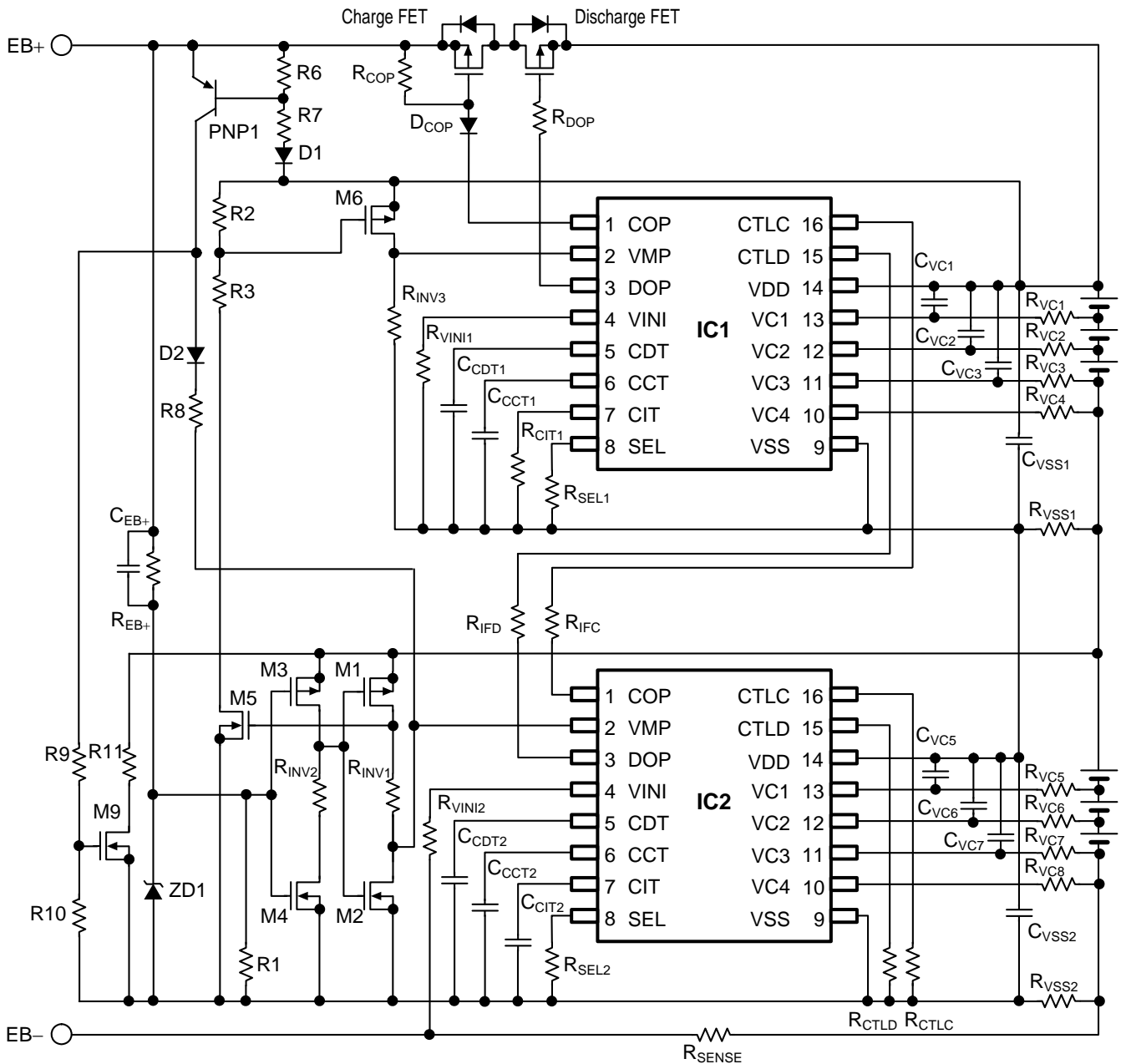

Remark Refer to "1.13 External parts list" for constants of external parts.

Figure 3

Caution 1. The above connection example may be changed without notice.

2. It has not been confirmed whether the operation is normal or not in circuits other than the above example of connection. The example of connection shown above will not guarantee successful operation.

1.4 Protection circuit with 6-series cell (with discharge overcurrent protect function, automatic recovery function and charge overcurrent protect function)

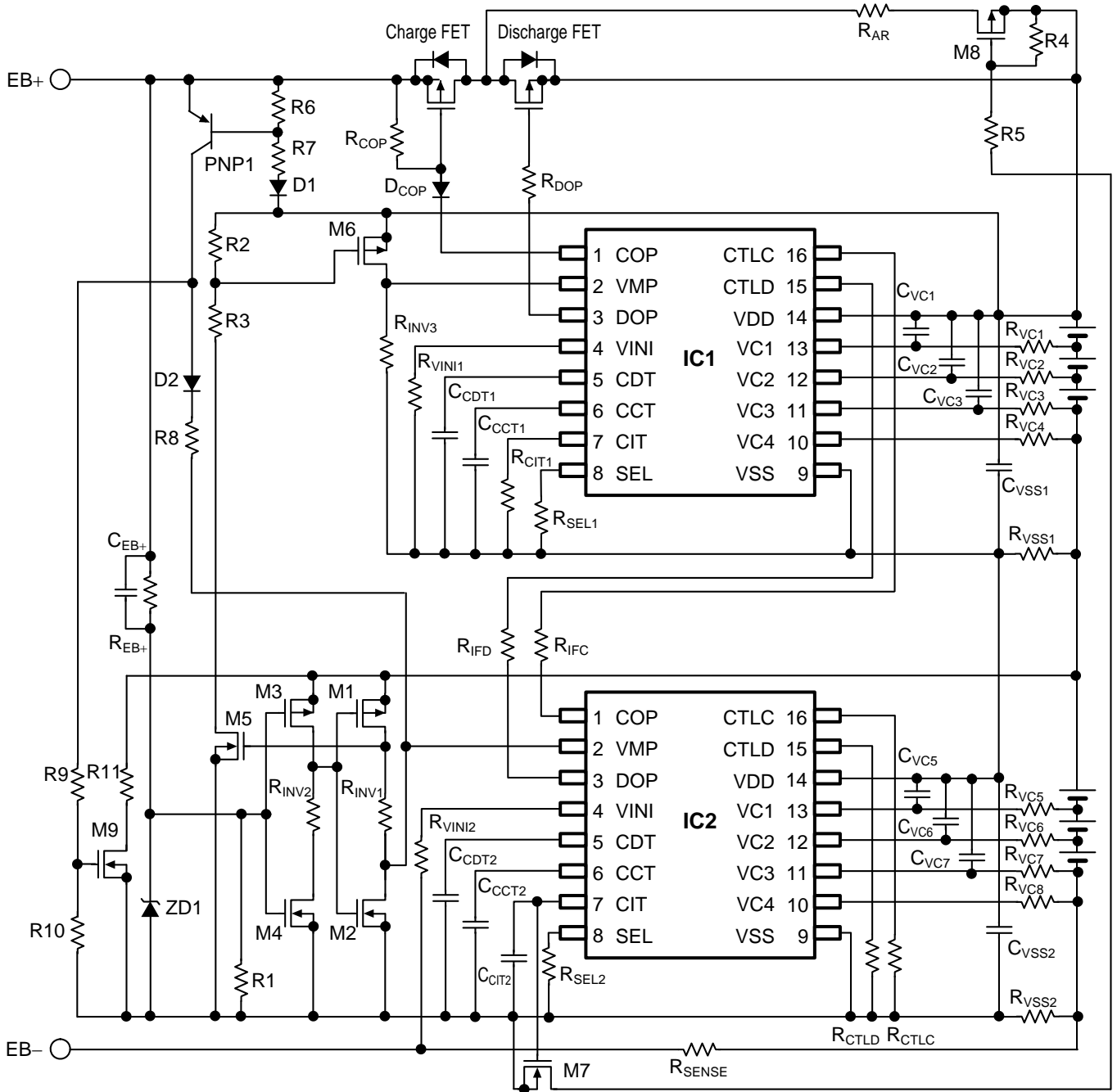

Remark Refer to "1.13 External parts list" for constants of external parts.

Figure 4

Caution 1. The above connection example may be changed without notice.

2. It has not been confirmed whether the operation is normal or not in circuits other than the above example of connection. The example of connection shown above will not guarantee successful operation.

1.5 Protection circuit with 7-series cell (with discharge overcurrent protect function)

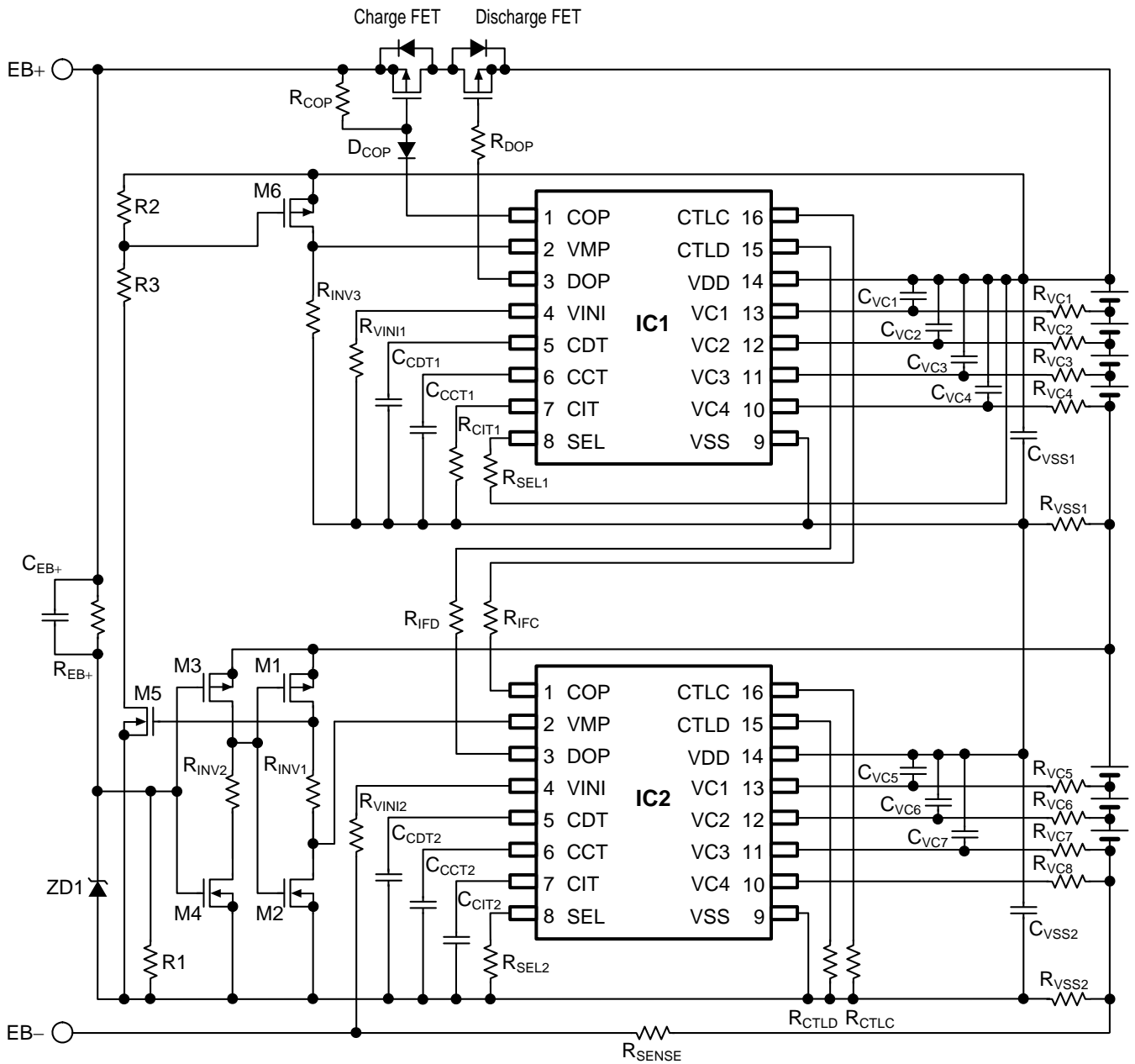

Remark Refer to "1.13 External parts list" for constants of external parts.

Figure 5

Caution 1. The above connection example may be changed without notice.

2. It has not been confirmed whether the operation is normal or not in circuits other than the above example of connection. The example of connection shown above will not guarantee successful operation.

1.6 Protection circuit with 7-series cell
(with discharge overcurrent protect function and automatic recovery function)

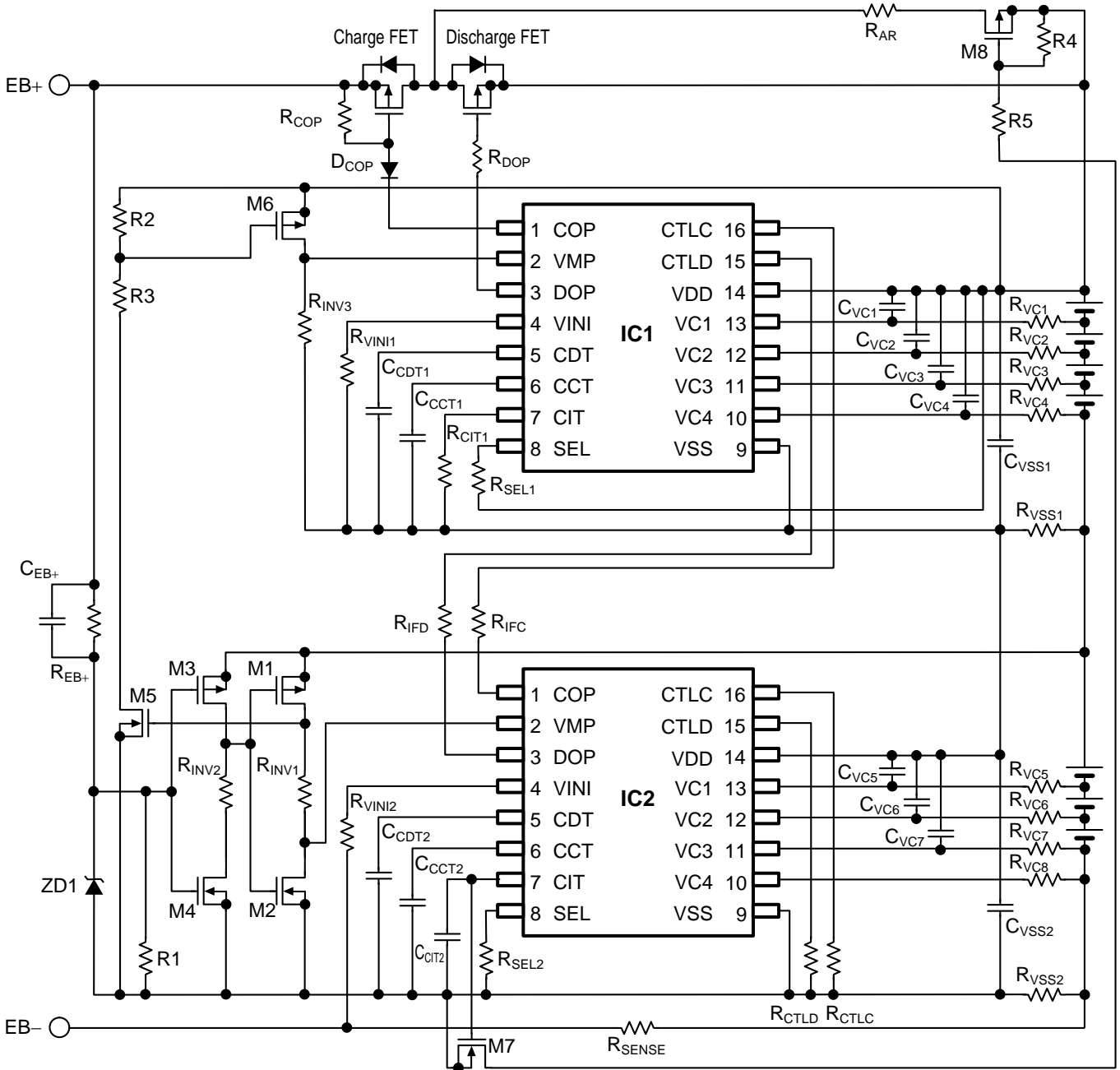

Remark Refer to "1.13 External parts list" for constants of external parts.

Figure 6

Caution 1. The above connection example may be changed without notice.

2. It has not been confirmed whether the operation is normal or not in circuits other than the above example of connection. The example of connection shown above will not guarantee successful operation.

**1.7 Protection circuit with 7-series cell
(with discharge overcurrent protect function and charge overcurrent protect function)**

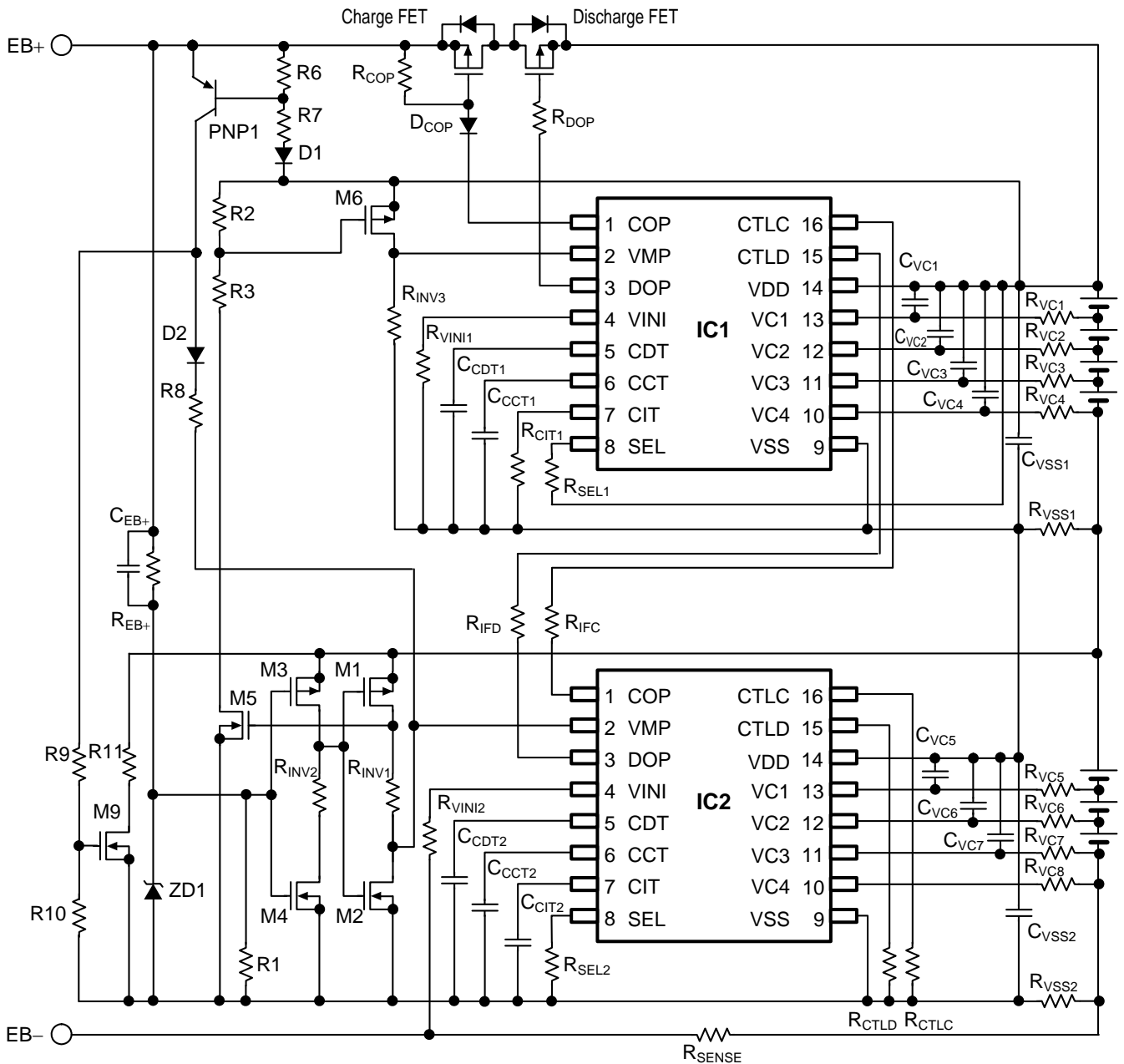

Remark Refer to "1.13 External parts list" for constants of external parts.

Figure 7

Caution 1. The above connection example may be changed without notice.

2. It has not been confirmed whether the operation is normal or not in circuits other than the above example of connection. The example of connection shown above will not guarantee successful operation.

1.8 Protection circuit with 7-series cell (with discharge overcurrent protect function, automatic recovery function and charge overcurrent protect function)

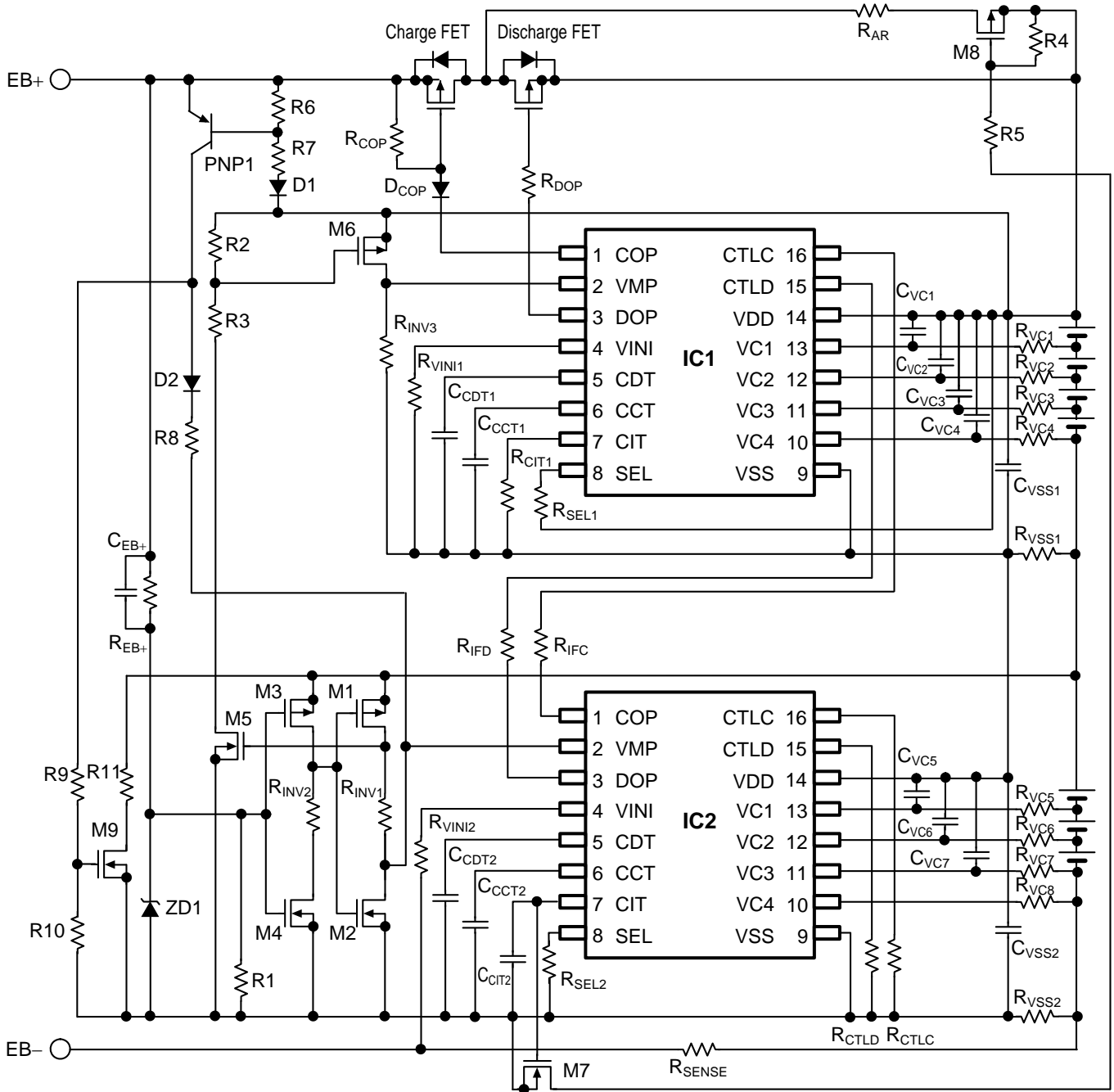

Remark Refer to "1.13 External parts list" for constants of external parts.

Figure 8

- Caution 1. The above connection example may be changed without notice.
2. It has not been confirmed whether the operation is normal or not in circuits other than the above example of connection. The example of connection shown above will not guarantee successful operation.

1.9 Protection circuit with 8-series cell (with discharge overcurrent protect function)

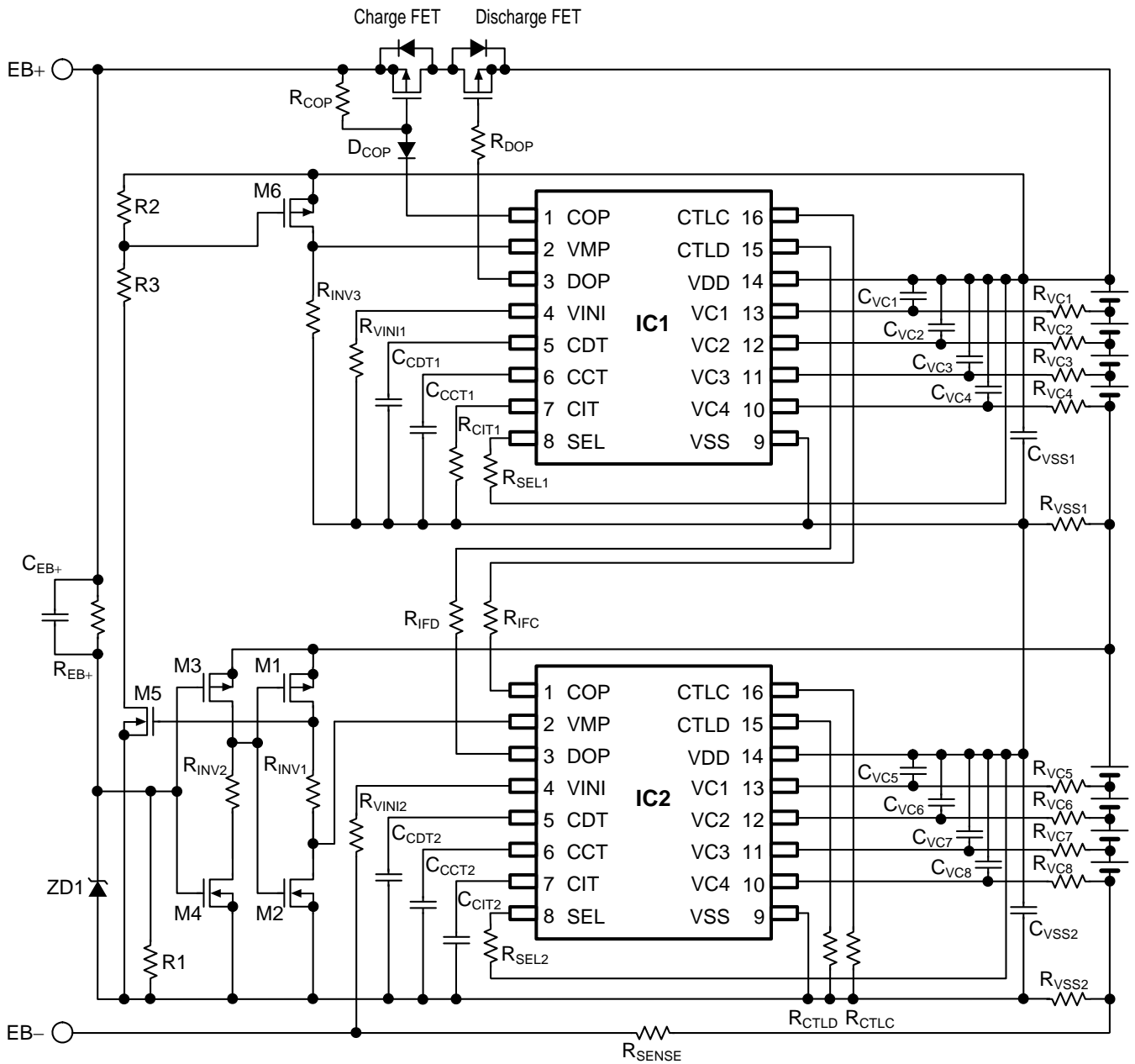

Remark Refer to "1.13 External parts list" for constants of external parts.

Figure 9

Caution 1. The above connection example may be changed without notice.

2. It has not been confirmed whether the operation is normal or not in circuits other than the above example of connection. The example of connection shown above will not guarantee successful operation.

**1. 10 Protection circuit with 8-series cell
(with discharge overcurrent protect function and automatic recovery function)**

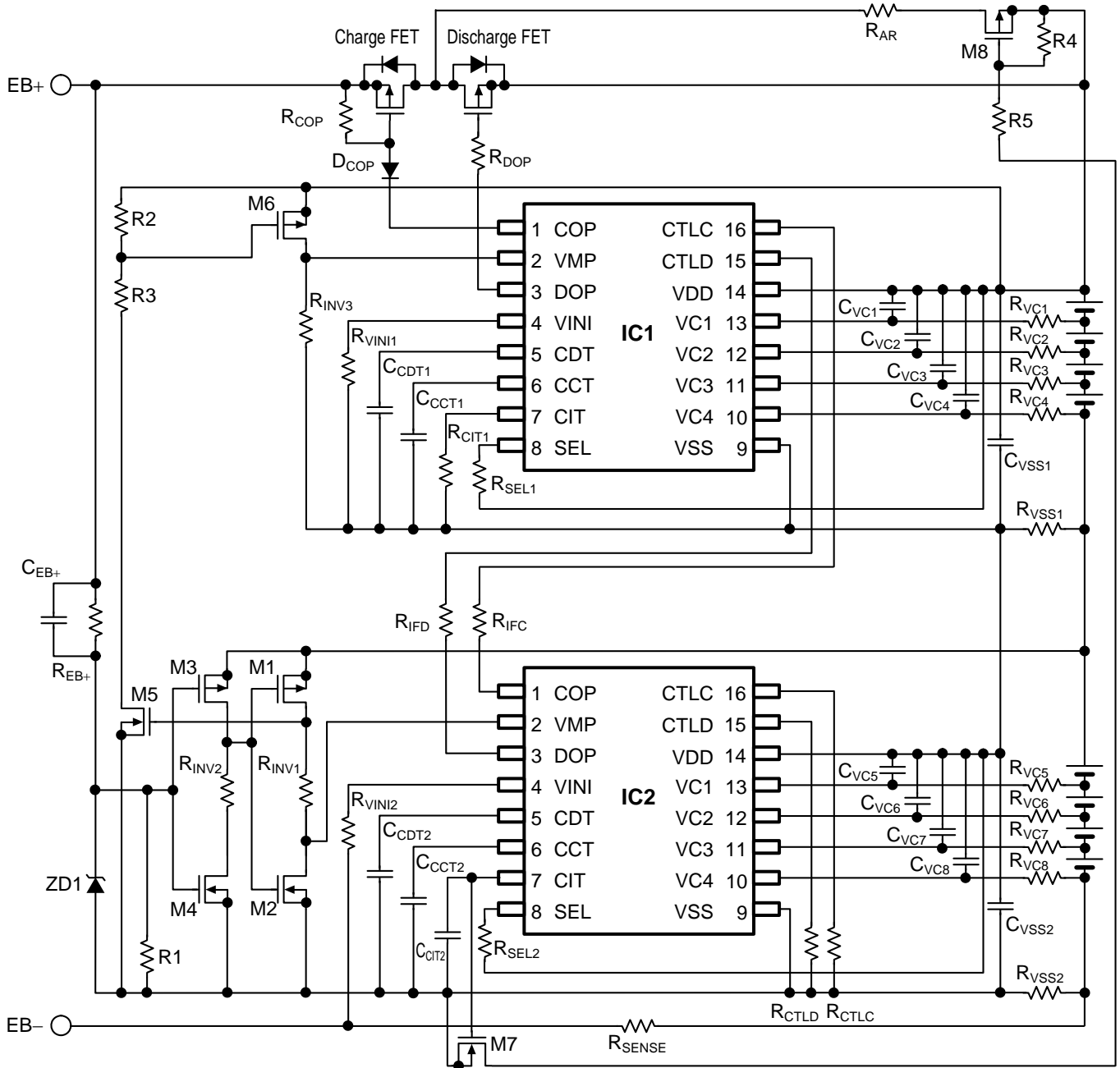

Remark Refer to "1. 13 External parts list" for constants of external parts.

Figure 10

- Caution 1.** The above connection example may be changed without notice.
- 2.** It has not been confirmed whether the operation is normal or not in circuits other than the above example of connection. The example of connection shown above will not guarantee successful operation.

**1.11 Protection circuit with 8-series cell
(with discharge overcurrent protect function and charge overcurrent protect function)**

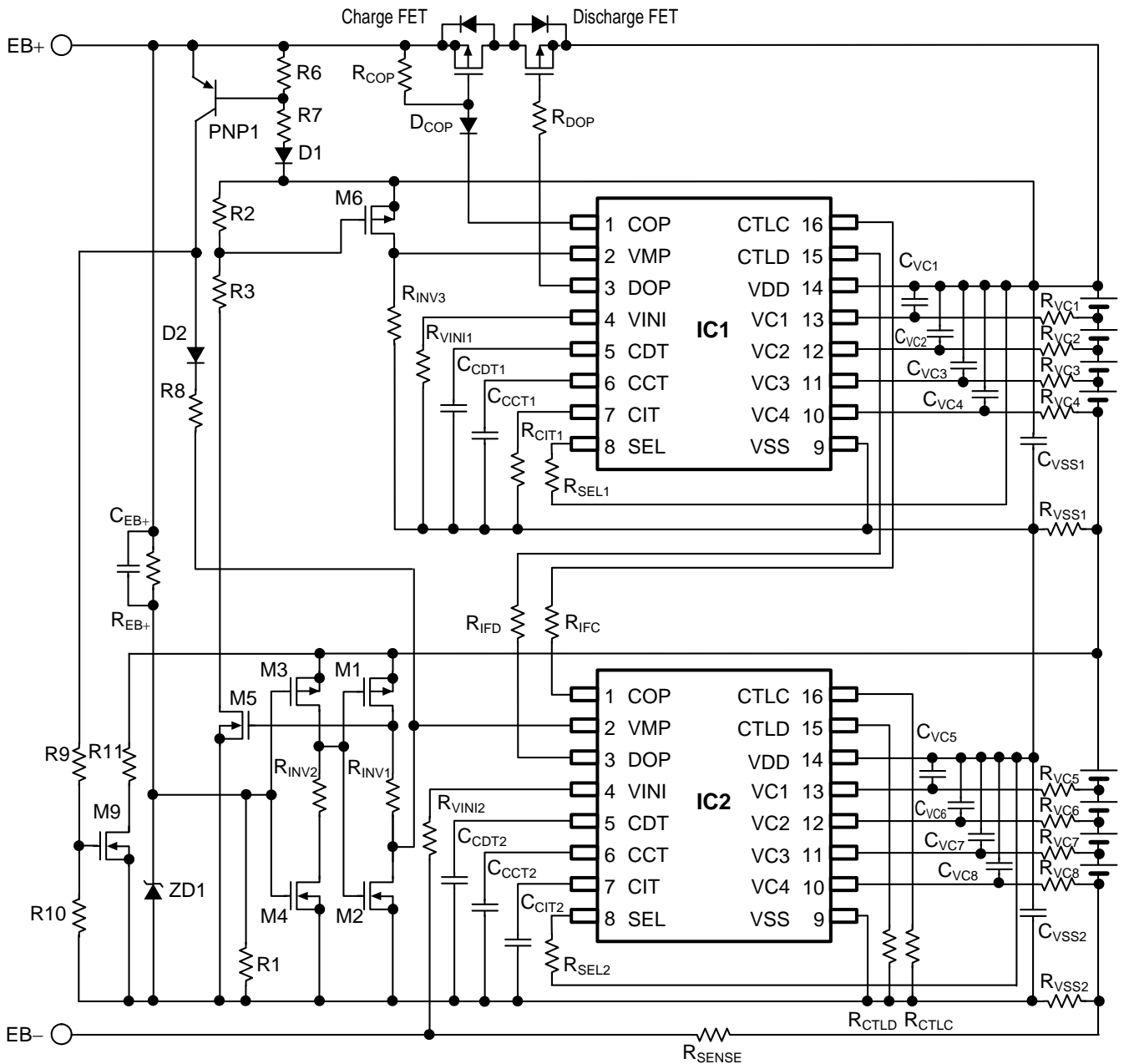

Remark Refer to "1.13 External parts list" for constants of external parts.

Figure 11

Caution 1. The above connection example may be changed without notice.

2. It has not been confirmed whether the operation is normal or not in circuits other than the above example of connection. The example of connection shown above will not guarantee successful operation.

S-8204A Series Connection Examples

1. 12 Protection circuit with 8-series cell (with discharge overcurrent protect function, automatic recovery function and charge overcurrent protect function)

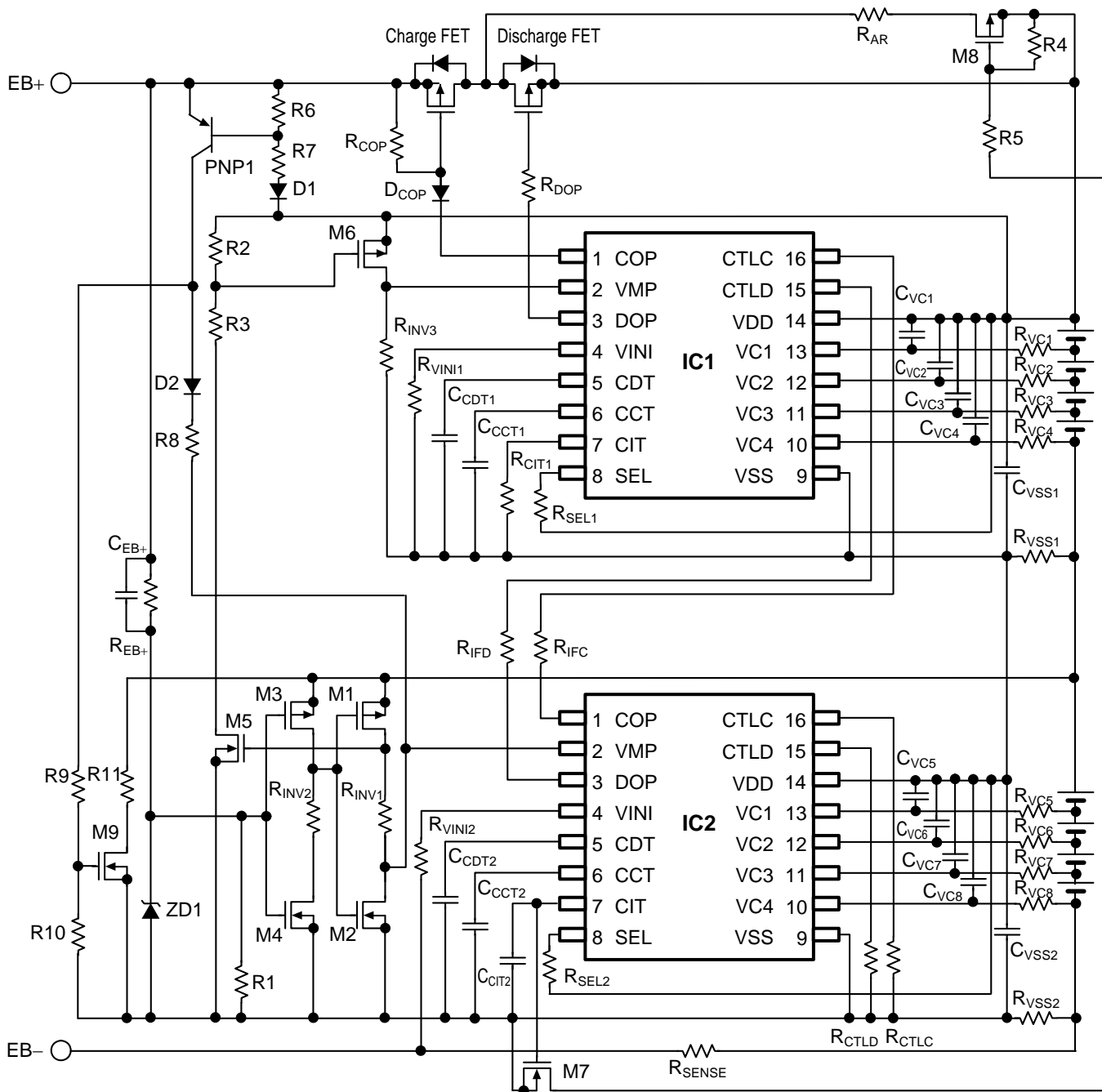

Remark Refer to "1. 13 External parts list" for constants of external parts.

Figure 12

- Caution 1.** The above connection example may be changed without notice.
- 2.** It has not been confirmed whether the operation is normal or not in circuits other than the above example of connection. The example of connection shown above will not guarantee successful operation.

1.13 External parts list

Table 1 shows external parts in the connection examples in Figure 1 to 12.

Table 1 (1 / 2)

Symbol	Typical	Unit	Parts name	Maker	Note
IC1	–	–	S-8204A	Seiko Instruments Inc.	Necessary
IC2	–	–	S-8204A	Seiko Instruments Inc.	Necessary
R _{Vc1}	1	kΩ	MCR03	ROHM CO., LTD.	Recommend
R _{Vc2}	1	kΩ	MCR03	ROHM CO., LTD.	Recommend
R _{Vc3}	1	kΩ	MCR03	ROHM CO., LTD.	Recommend
R _{Vc4}	1	kΩ	MCR03	ROHM CO., LTD.	Recommend
R _{Vc5}	1	kΩ	MCR03	ROHM CO., LTD.	Recommend
R _{Vc6}	1	kΩ	MCR03	ROHM CO., LTD.	Recommend
R _{Vc7}	1	kΩ	MCR03	ROHM CO., LTD.	Recommend
R _{Vc8}	1	kΩ	MCR03	ROHM CO., LTD.	Recommend
C _{Vc1}	0.047	μF	GRM188B	Murata Manufacturing Co., Ltd.	Recommend
C _{Vc2}	0.047	μF	GRM188B	Murata Manufacturing Co., Ltd.	Recommend
C _{Vc3}	0.047	μF	GRM188B	Murata Manufacturing Co., Ltd.	Recommend
C _{Vc4}	0.047	μF	GRM188B	Murata Manufacturing Co., Ltd.	Recommend
C _{Vc5}	0.047	μF	GRM188B	Murata Manufacturing Co., Ltd.	Recommend
C _{Vc6}	0.047	μF	GRM188B	Murata Manufacturing Co., Ltd.	Recommend
C _{Vc7}	0.047	μF	GRM188B	Murata Manufacturing Co., Ltd.	Recommend
C _{Vc8}	0.047	μF	GRM188B	Murata Manufacturing Co., Ltd.	Recommend
R _{VSS1}	47	Ω	MCR03	ROHM CO., LTD.	Recommend
R _{VSS2}	47	Ω	MCR03	ROHM CO., LTD.	Recommend
C _{VSS1}	1.5	μF	GRM188B	Murata Manufacturing Co., Ltd.	Recommend
C _{VSS2}	1	μF	GRM188B	Murata Manufacturing Co., Ltd.	Recommend
R _{SEL1}	1	kΩ	MCR03	ROHM CO., LTD.	Recommend
R _{SEL2}	1	kΩ	MCR03	ROHM CO., LTD.	Recommend
C _{CCT1}	0.1	μF	GRM188B	Murata Manufacturing Co., Ltd.	–
C _{CCT2}	0.1	μF	GRM188B	Murata Manufacturing Co., Ltd.	–
C _{CDT1}	0.1	μF	GRM188B	Murata Manufacturing Co., Ltd.	–
C _{CDT2}	0.1	μF	GRM188B	Murata Manufacturing Co., Ltd.	–
R _{CIT1}	1	kΩ	MCR03	ROHM CO., LTD.	Recommend
C _{CIT2}	0.1	μF	GRM188B	Murata Manufacturing Co., Ltd.	–
R _{VINI1}	1	kΩ	MCR03	ROHM CO., LTD.	Recommend
R _{VINI2}	1	kΩ	MCR03	ROHM CO., LTD.	Recommend
R _{CTLc}	1	kΩ	MCR03	ROHM CO., LTD.	Recommend
R _{CTLd}	1	kΩ	MCR03	ROHM CO., LTD.	Recommend
R _{IFC}	5.1	MΩ	MCR03	ROHM CO., LTD.	Necessary
R _{IFD}	5.1	MΩ	MCR03	ROHM CO., LTD.	Necessary
R _{COP}	1	MΩ	MCR03	ROHM CO., LTD.	Recommend
R _{DOP}	51	kΩ	MCR03	ROHM CO., LTD.	Recommend
D _{COP}	–	–	1SS355	ROHM CO., LTD.	Recommend
D1	–	–	1SS355	ROHM CO., LTD.	Recommend
D2	–	–	1SS355	ROHM CO., LTD.	Recommend
R _{SENSE}	–	–	–	–	–

Table 1 (1 / 2)

Symbol	Typical	Unit	Parts name	Maker	Note
M1	–	–	2SJ210	NEC Electronics Corporation	Recommend
M2	–	–	2SK1590	NEC Electronics Corporation	Recommend
M3	–	–	2SJ210	NEC Electronics Corporation	Recommend
M4	–	–	2SK1590	NEC Electronics Corporation	Recommend
M5	–	–	2SK1590	NEC Electronics Corporation	Recommend
M6	–	–	2SJ210	NEC Electronics Corporation	Recommend
M7	–	–	2SK1590	NEC Electronics Corporation	Recommend
M8	–	–	2SJ210	NEC Electronics Corporation	Recommend
M9	–	–	2SK1590	NEC Electronics Corporation	Recommend
PNP1	–	–	2SA1037AK	ROHM CO., LTD.	Recommend
R _{INV1}	5.1	kΩ	MCR03	ROHM CO., LTD.	Necessary
R _{INV2}	1	MΩ	MCR03	ROHM CO., LTD.	Recommend
R _{INV3}	10	MΩ	MCR03	ROHM CO., LTD.	Recommend
R1	10	MΩ	–	–	Recommend
R2	10	MΩ	–	–	Recommend
R3	10	MΩ	–	–	Recommend
R4	1	MΩ	MCR03	ROHM CO., LTD.	Recommend
R5	1	MΩ	MCR03	ROHM CO., LTD.	Recommend
R6	1	MΩ	MCR03	ROHM CO., LTD.	Recommend
R7	1	MΩ	MCR03	ROHM CO., LTD.	Recommend
R8	270	kΩ	MCR03	ROHM CO., LTD.	Necessary
R9	5.1	MΩ	MCR03	ROHM CO., LTD.	Recommend
R10	1	MΩ	MCR03	ROHM CO., LTD.	Recommend
R11	270	kΩ	MCR03	ROHM CO., LTD.	Necessary
ZD1	–	–	UDZS18B	ROHM CO., LTD.	Recommend
R _{EB+}	3	MΩ	MCR03	ROHM CO., LTD.	Recommend
C _{EB+}	100	pF	GRM188B	Murata Manufacturing Co., Ltd.	Recommend
R _{AR}	100	kΩ	MCR03	ROHM CO., LTD.	Recommend
Charge FET	–	–	–	–	–
Discharge FET	–	–	–	–	–

Caution 1. The above constants are subject to change without prior notice.

2. These constant will not guarantee successful operation. Perform thorough evaluation using the actual application to set the constant.

2. Precaution

- The usage described in this application note is typical example with our IC.
Perform evaluation fully before use.
- When designing for mass production using an application circuit described herein, the product deviation and temperature characteristics of the external parts should be taken into consideration. SII shall not bear any responsibility for patent infringements related to products using the circuits described herein.
- SII claims no responsibility for any disputes arising out of or in connection with any infringement by products including this IC of patents owned by a third party.

3. Related source

Refer to the following datasheet for details of the S-8204A Series.

S-8204A Series Datasheet

The information described herein is subject to change without notice.

Regarding the newest version, contact our sales office.

Select product category and product name on our SII semiconductors website, download the PDF file.

www.sii-ic.com **SII semiconductors website**



Seiko Instruments Inc.
www.sii-ic.com

- The information described herein is subject to change without notice.
- Seiko Instruments Inc. is not responsible for any problems caused by circuits or diagrams described herein whose related industrial properties, patents, or other rights belong to third parties. The application circuit examples explain typical applications of the products, and do not guarantee the success of any specific mass-production design.
- When the products described herein are regulated products subject to the Wassenaar Arrangement or other agreements, they may not be exported without authorization from the appropriate governmental authority.
- Use of the information described herein for other purposes and/or reproduction or copying without the express permission of Seiko Instruments Inc. is strictly prohibited.
- The products described herein cannot be used as part of any device or equipment affecting the human body, such as exercise equipment, medical equipment, security systems, gas equipment, or any apparatus installed in airplanes and other vehicles, without prior written permission of Seiko Instruments Inc.
- Although Seiko Instruments Inc. exerts the greatest possible effort to ensure high quality and reliability, the failure or malfunction of semiconductor products may occur. The user of these products should therefore give thorough consideration to safety design, including redundancy, fire-prevention measures, and malfunction prevention, to prevent any accidents, fires, or community damage that may ensue.