

## LOW VOLTAGE OPERATION BOTH POLES / UNIPOLAR DETECTION TYPE HALL IC

The S-5712 Series, developed by CMOS technology, is a high-accuracy Hall IC that operates at a low voltage and low current consumption.

The output voltage changes when the S-5712 Series detects the intensity level of flux density. Using the S-5712 Series with a magnet makes it possible to detect the open / close state in various devices.

High-density mounting is possible by using the small SOT-23-3 or the super-small SNT-4A packages. Due to its low voltage operation and low current consumption, the S-5712 Series is suitable for battery-operated portable devices. Due to its high-accuracy magnetic characteristics, the S-5712 Series can make operation's dispersion in the system combined with magnet smaller.

**Caution** This product is intended to use in general electronic devices such as consumer electronics, office equipment, and communications devices. Before using the product in medical equipment or automobile equipment including car audio, keyless entry and engine control unit, contact to SII is indispensable.

### ■ Features

- |   |  |
|---|--|
| • Pole detection <sup>*1</sup> :                  | Detection of both poles, south pole or north pole  |
| • Detection logic for magnetism <sup>*1</sup> :   | Active "L", active "H"   |
| • Output form <sup>*1</sup> :                     | Nch open drain output, CMOS output   |
| • Magnetic sensitivity <sup>*1</sup> :            | $B_{OP} = 3.0 \text{ mT typ.}, 4.5 \text{ mT typ.}$  |
| • Operating cycle (current consumption):          | Product with both poles detection<br>50.50 ms (2.0 $\mu\text{A}$ ) typ.<br>Product with south pole or north pole detection<br>50.85 ms (1.4 $\mu\text{A}$ ) typ. |
| • Power supply voltage range:                     | 1.6 V to 3.5 V   |
| • Operation temperature range:                    | $T_a = -40^\circ\text{C to } +85^\circ\text{C}$  |
| • Lead-free (Sn 100%), halogen-free <sup>*2</sup> |  |

\*1. The Option can be selected.

\*2. Refer to "■ Product Name Structure" for details.

### ■ Applications

- Mobile phone (flip type, slide type, etc.)
- Laptop PC
- Digital video camera
- Plaything, portable game
- Home appliance

### ■ Packages

- SOT-23-3
- SNT-4A

■ Block Diagrams

1. Nch open drain output product

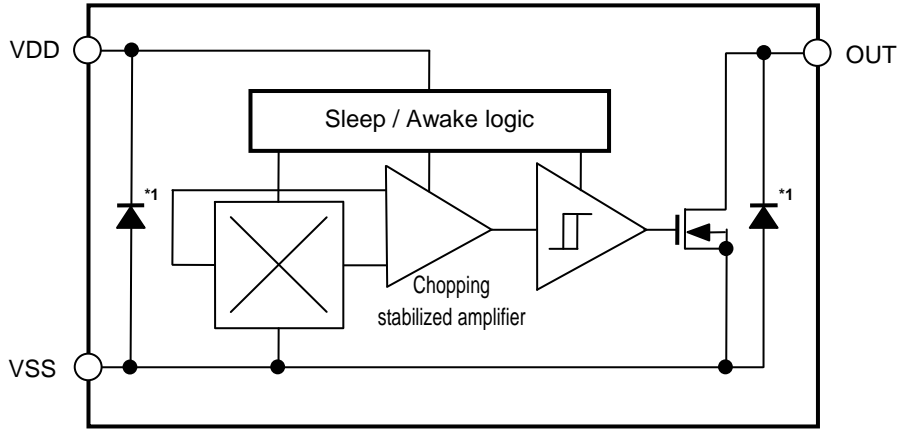

\*1. Parasitic diode

Figure 1

2. CMOS output product

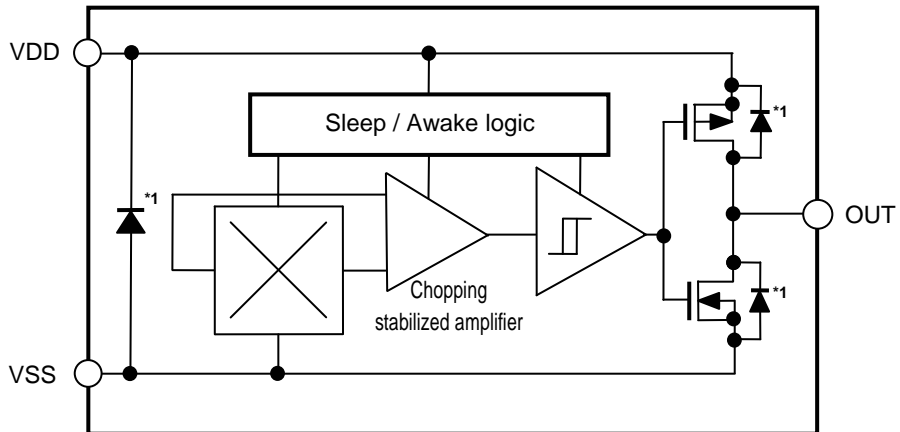

\*1. Parasitic diode

Figure 2

■ Product Name Structure

1. Product name

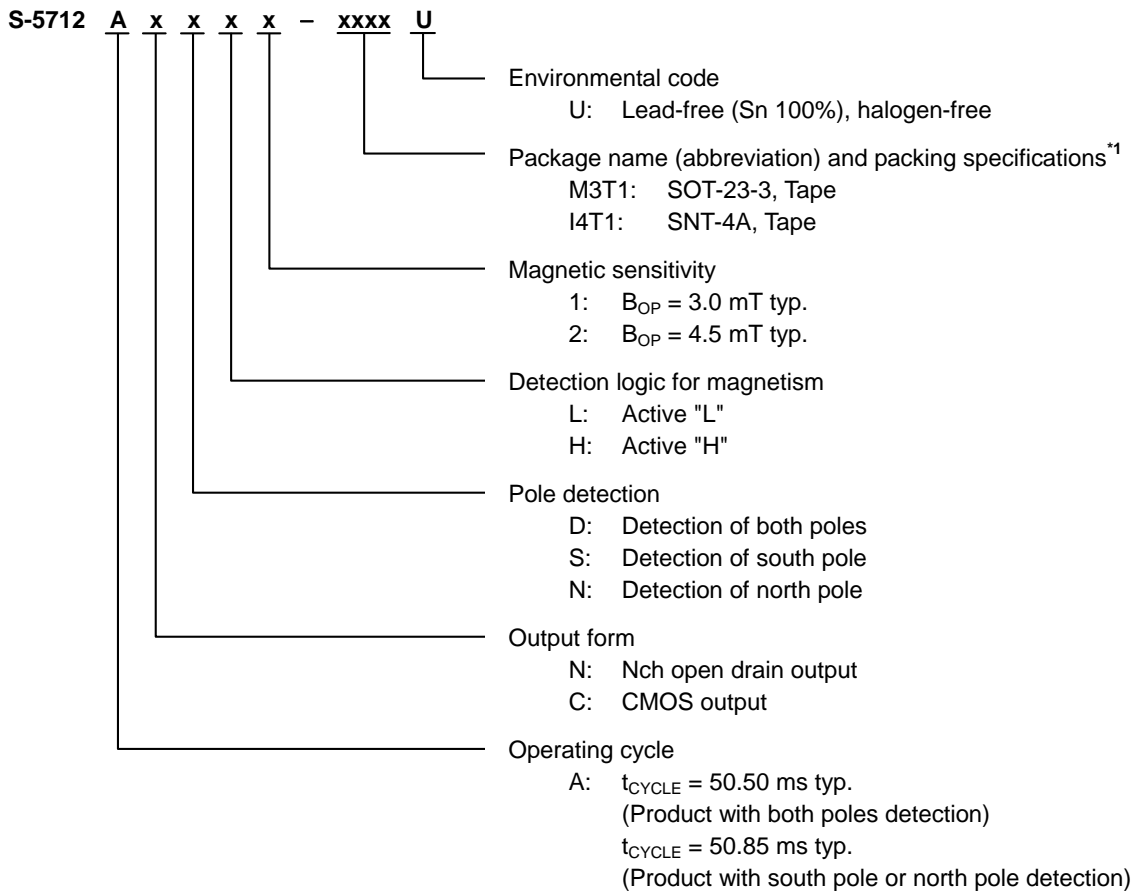

\*1. Refer to the tape specifications.

2. Packages

Table 1 Package Drawing Code

Package name	Dimension	Tape	Reel	Land
SOT-23-3	MP003-C-P-SD	MP003-C-C-SD	MP003-Z-R-SD	-
SNT-4A	PF004-A-P-SD	PF004-A-C-SD	PF004-A-R-SD	PF004-A-L-SD

**3. Product name list**

**3.1 SOT-23-3**

**3.1.1 Nch open drain output product**

**Table 2**

Product Name	Output Form	Pole Detection	Detection Logic for Magnetism	Magnetic Sensitivity (B <sub>OP</sub> )
S-5712ANDL1-M3T1U	Nch open drain output	Both poles	Active "L"	3.0 mT typ.
S-5712ANDL2-M3T1U	Nch open drain output	Both poles	Active "L"	4.5 mT typ.
S-5712ANSL1-M3T1U	Nch open drain output	South pole	Active "L"	3.0 mT typ.
S-5712ANSL2-M3T1U	Nch open drain output	South pole	Active "L"	4.5 mT typ.

**Remark** Please contact our sales office for products other than the above.

**3.1.2 CMOS output product**

**Table 3**

Product Name	Output Form	Pole Detection	Detection Logic for Magnetism	Magnetic Sensitivity (B <sub>OP</sub> )
S-5712ACDL1-M3T1U	CMOS output	Both poles	Active "L"	3.0 mT typ.
S-5712ACDL2-M3T1U	CMOS output	Both poles	Active "L"	4.5 mT typ.
S-5712ACDH1-M3T1U	CMOS output	Both poles	Active "H"	3.0 mT typ.
S-5712ACDH2-M3T1U	CMOS output	Both poles	Active "H"	4.5 mT typ.
S-5712ACSL1-M3T1U	CMOS output	South pole	Active "L"	3.0 mT typ.
S-5712ACSL2-M3T1U	CMOS output	South pole	Active "L"	4.5 mT typ.
S-5712ACNL1-M3T1U	CMOS output	North pole	Active "L"	3.0 mT typ.
S-5712ACNL2-M3T1U	CMOS output	North pole	Active "L"	4.5 mT typ.

**Remark** Please contact our sales office for products other than the above.

**3.2 SNT-4A**

**3.2.1 Nch open drain output product**

**Table 4**

Product Name	Output Form	Pole Detection	Detection Logic for Magnetism	Magnetic Sensitivity (B <sub>OP</sub> )
S-5712ANDL1-I4T1U	Nch open drain output	Both poles	Active "L"	3.0 mT typ.
S-5712ANDL2-I4T1U	Nch open drain output	Both poles	Active "L"	4.5 mT typ.
S-5712ANSL1-I4T1U	Nch open drain output	South pole	Active "L"	3.0 mT typ.
S-5712ANSL2-I4T1U	Nch open drain output	South pole	Active "L"	4.5 mT typ.

**Remark** Please contact our sales office for products other than the above.

**3.2.2 CMOS output product**

**Table 5**

Product Name	Output Form	Pole Detection	Detection Logic for Magnetism	Magnetic Sensitivity (B <sub>OP</sub> )
S-5712ACDL1-I4T1U	CMOS output	Both poles	Active "L"	3.0 mT typ.
S-5712ACDL2-I4T1U	CMOS output	Both poles	Active "L"	4.5 mT typ.
S-5712ACDH1-I4T1U	CMOS output	Both poles	Active "H"	3.0 mT typ.
S-5712ACDH2-I4T1U	CMOS output	Both poles	Active "H"	4.5 mT typ.
S-5712ACSL1-I4T1U	CMOS output	South pole	Active "L"	3.0 mT typ.
S-5712ACSL2-I4T1U	CMOS output	South pole	Active "L"	4.5 mT typ.
S-5712ACNL1-I4T1U	CMOS output	North pole	Active "L"	3.0 mT typ.
S-5712ACNL2-I4T1U	CMOS output	North pole	Active "L"	4.5 mT typ.

**Remark** Please contact our sales office for products other than the above.

■ Pin Configurations

1. SOT-23-3

SOT-23-3  
Top view

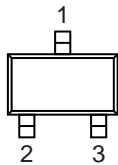

Figure 3

Table 6

Pin No.	Symbol	Pin Description
1	VSS	GND pin
2	VDD	Power supply pin
3	OUT	Output pin

2. SNT-4A

SNT-4A  
Top view

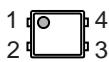

Figure 4

Table 7

Pin No.	Symbol	Pin Description
1	VDD	Power supply pin
2	VSS	GND pin
3	NC <sup>*1</sup>	No connection
4	OUT	Output pin

\*1. The NC pin is electrically open.

The NC pin can be connected to VDD or VSS.

■ Absolute Maximum Ratings

Table 8

(Ta = +25°C unless otherwise specified)

Item	Symbol	Absolute Maximum Rating	Unit
Power supply voltage	$V_{DD}$	$V_{SS} - 0.3$ to $V_{SS} + 7.0$	V
Output current	$I_{OUT}$	$\pm 1.0$	mA
Output voltage	Nch open drain output	$V_{OUT}$	$V_{SS} - 0.3$ to $V_{SS} + 7.0$
	CMOS output		$V_{SS} - 0.3$ to $V_{DD} + 0.3$
Power dissipation	SOT-23-3	$P_D$	430 <sup>*1</sup>
	SNT-4A		300 <sup>*1</sup>
Operating ambient temperature	$T_{opr}$	-40 to +85	°C
Storage temperature	$T_{stg}$	-40 to +125	°C

\*1. When mounted on board

[Mounted board]

- (1) Board size: 114.3 mm × 76.2 mm × t1.6 mm
- (2) Name: JEDEC STANDARD51-7

**Caution** The absolute maximum ratings are rated values exceeding which the product could suffer physical damage. These values must therefore not be exceeded under any conditions.

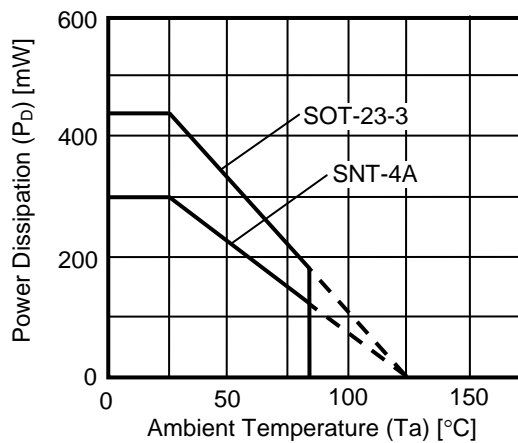

Figure 5 Power Dissipation of Package (When Mounted on Board)

■ Electrical Characteristics

1. Product with both poles detection

Table 9

(Ta = +25°C, V<sub>DD</sub> = 1.85 V, V<sub>SS</sub> = 0 V unless otherwise specified)

Item	Symbol	Condition	Min.	Typ.	Max.	Unit	Test Circuit	
Power supply voltage	V <sub>DD</sub>	–	1.60	1.85	3.50	V	–	
Current consumption	I <sub>DD</sub>	Average value	–	2.0	4.0	μA	1	
Output voltage	V <sub>OUT</sub>	Nch open drain output product	Output transistor Nch, I <sub>OUT</sub> = 0.5 mA	–	–	0.4	V	2
		CMOS output product	Output transistor Nch, I <sub>OUT</sub> = 0.5 mA	–	–	0.4	V	2
			Output transistor Pch, I <sub>OUT</sub> = –0.5 mA	V <sub>DD</sub> – 0.4	–	–	V	3
Leakage current	I <sub>LEAK</sub>	Nch open drain output product Output transistor Nch, V <sub>OUT</sub> = 3.5 V	–	–	1	μA	4	
Awake mode time	t <sub>AW</sub>	–	–	0.10	–	ms	–	
Sleep mode time	t <sub>SL</sub>	–	–	50.40	–	ms	–	
Operating cycle	t <sub>CYCLE</sub>	t <sub>AW</sub> + t <sub>SL</sub>	–	50.50	100.00	ms	–	

2. Product with south pole and north pole detection

Table 10

(Ta = +25°C, V<sub>DD</sub> = 1.85 V, V<sub>SS</sub> = 0 V unless otherwise specified)

Item	Symbol	Condition	Min.	Typ.	Max.	Unit	Test Circuit	
Power supply voltage	V <sub>DD</sub>	–	1.60	1.85	3.50	V	–	
Current consumption	I <sub>DD</sub>	Average value	–	1.4	3.0	μA	1	
Output voltage	V <sub>OUT</sub>	Nch open drain output product	Output transistor Nch, I <sub>OUT</sub> = 0.5 mA	–	–	0.4	V	2
		CMOS output product	Output transistor Nch, I <sub>OUT</sub> = 0.5 mA	–	–	0.4	V	2
			Output transistor Pch, I <sub>OUT</sub> = –0.5 mA	V <sub>DD</sub> – 0.4	–	–	V	3
Leakage current	I <sub>LEAK</sub>	Nch open drain output product Output transistor Nch, V <sub>OUT</sub> = 3.5 V	–	–	1	μA	4	
Awake mode time	t <sub>AW</sub>	–	–	0.05	–	ms	–	
Sleep mode time	t <sub>SL</sub>	–	–	50.80	–	ms	–	
Operating cycle	t <sub>CYCLE</sub>	t <sub>AW</sub> + t <sub>SL</sub>	–	50.85	100.00	ms	–	

■ Magnetic Characteristics

1. Product with both poles detection

1.1  $B_{OP} = 3.0 \text{ mT typ.}$

Table 11

( $T_a = +25^\circ\text{C}$ ,  $V_{DD} = 1.85 \text{ V}$ ,  $V_{SS} = 0 \text{ V}$  unless otherwise specified)

Item	Symbol	Condition	Min.	Typ.	Max.	Unit	Test Circuit	
Operating point* <sup>1</sup>	South pole	$B_{OPS}$	–	1.4	3.0	4.0	mT	5
	North pole	$B_{OPN}$	–	–4.0	–3.0	–1.4	mT	5
Release point* <sup>2</sup>	South pole	$B_{RPS}$	–	1.1	2.2	3.7	mT	5
	North pole	$B_{RPN}$	–	–3.7	–2.2	–1.1	mT	5
Hysteresis width* <sup>3</sup>	South pole	$B_{HYSS}$	$B_{HYSS} = B_{OPS} - B_{RPS}$	–	0.8	–	mT	5
	North pole	$B_{HYSN}$	$B_{HYSN} =  B_{OPN} - B_{RPN} $	–	0.8	–	mT	5

1.2  $B_{OP} = 4.5 \text{ mT typ.}$

Table 12

( $T_a = +25^\circ\text{C}$ ,  $V_{DD} = 1.85 \text{ V}$ ,  $V_{SS} = 0 \text{ V}$  unless otherwise specified)

Item	Symbol	Condition	Min.	Typ.	Max.	Unit	Test Circuit	
Operating point* <sup>1</sup>	South pole	$B_{OPS}$	–	2.5	4.5	6.0	mT	5
	North pole	$B_{OPN}$	–	–6.0	–4.5	–2.5	mT	5
Release point* <sup>2</sup>	South pole	$B_{RPS}$	–	2.0	3.5	5.5	mT	5
	North pole	$B_{RPN}$	–	–5.5	–3.5	–2.0	mT	5
Hysteresis width* <sup>3</sup>	South pole	$B_{HYSS}$	$B_{HYSS} = B_{OPS} - B_{RPS}$	–	1.0	–	mT	5
	North pole	$B_{HYSN}$	$B_{HYSN} =  B_{OPN} - B_{RPN} $	–	1.0	–	mT	5

2. Product with south pole detection

2.1  $B_{OP} = 3.0 \text{ mT typ.}$

Table 13

( $T_a = +25^\circ\text{C}$ ,  $V_{DD} = 1.85 \text{ V}$ ,  $V_{SS} = 0 \text{ V}$  unless otherwise specified)

Item	Symbol	Condition	Min.	Typ.	Max.	Unit	Test Circuit	
Operating point* <sup>1</sup>	South pole	$B_{OPS}$	–	1.4	3.0	4.0	mT	5
Release point* <sup>2</sup>	South pole	$B_{RPS}$	–	1.1	2.2	3.7	mT	5
Hysteresis width* <sup>3</sup>	South pole	$B_{HYSS}$	$B_{HYSS} = B_{OPS} - B_{RPS}$	–	0.8	–	mT	5

2.2  $B_{OP} = 4.5 \text{ mT typ.}$

Table 14

( $T_a = +25^\circ\text{C}$ ,  $V_{DD} = 1.85 \text{ V}$ ,  $V_{SS} = 0 \text{ V}$  unless otherwise specified)

Item	Symbol	Condition	Min.	Typ.	Max.	Unit	Test Circuit	
Operating point* <sup>1</sup>	South pole	$B_{OPS}$	–	2.5	4.5	6.0	mT	5
Release point* <sup>2</sup>	South pole	$B_{RPS}$	–	2.0	3.5	5.5	mT	5
Hysteresis width* <sup>3</sup>	South pole	$B_{HYSS}$	$B_{HYSS} = B_{OPS} - B_{RPS}$	–	1.0	–	mT	5

### 3. Product with north pole detection

#### 3.1 $B_{OP} = 3.0$ mT typ.

**Table 15**

(Ta = +25°C, V<sub>DD</sub> = 1.85 V, V<sub>SS</sub> = 0 V unless otherwise specified)

Item	Symbol	Condition	Min.	Typ.	Max.	Unit	Test Circuit		
Operating point <sup>*1</sup>	North pole	B <sub>OPN</sub>	-	-4.0	-3.0	-1.4	mT	5	
Release point <sup>*2</sup>	North pole	B <sub>RPN</sub>	-	-3.7	-2.2	-1.1	mT	5	
Hysteresis width <sup>*3</sup>	North pole	B <sub>HYSN</sub>	B <sub>HYSN</sub> =  B <sub>OPN</sub> - B <sub>RPN</sub>		-	0.8	-	mT	5

#### 3.2 $B_{OP} = 4.5$ mT typ.

**Table 16**

(Ta = +25°C, V<sub>DD</sub> = 1.85 V, V<sub>SS</sub> = 0 V unless otherwise specified)

Item	Symbol	Condition	Min.	Typ.	Max.	Unit	Test Circuit		
Operating point <sup>*1</sup>	North pole	B <sub>OPN</sub>	-	-6.0	-4.5	-2.5	mT	5	
Release point <sup>*2</sup>	North pole	B <sub>RPN</sub>	-	-5.5	-3.5	-2.0	mT	5	
Hysteresis width <sup>*3</sup>	North pole	B <sub>HYSN</sub>	B <sub>HYSN</sub> =  B <sub>OPN</sub> - B <sub>RPN</sub>		-	1.0	-	mT	5

**\*1. B<sub>OPN</sub>, B<sub>OPS</sub>: Operating points**

The operating points are the values of magnetic flux density when the output voltage (V<sub>OUT</sub>) is inverted after the magnetic flux density applied to the S-5712 Series by the magnet (north or south pole) is increased (the magnet is moved closer). Even when the magnetic flux density exceeds B<sub>OPN</sub> or B<sub>OPS</sub>, V<sub>OUT</sub> retains the status.

**\*2. B<sub>RPN</sub>, B<sub>RPS</sub>: Release points**

The release points are the values of magnetic flux density when the output voltage (V<sub>OUT</sub>) is inverted after the magnetic flux density applied to the S-5712 Series by the magnet (north or south pole) is decreased (the magnet is moved further away).

Even when the magnetic flux density falls below B<sub>RPN</sub> or B<sub>RPS</sub>, V<sub>OUT</sub> retains the status.

**\*3. B<sub>HYSN</sub>, B<sub>HYS</sub>: Hysteresis widths**

B<sub>HYSN</sub> and B<sub>HYS</sub> are the difference between B<sub>OPN</sub> and B<sub>RPN</sub>, and B<sub>OPS</sub> and B<sub>RPS</sub>, respectively.

**Remark** The unit of magnetic density mT can be converted by using the formula 1 mT = 10 Gauss.

■ Test Circuits

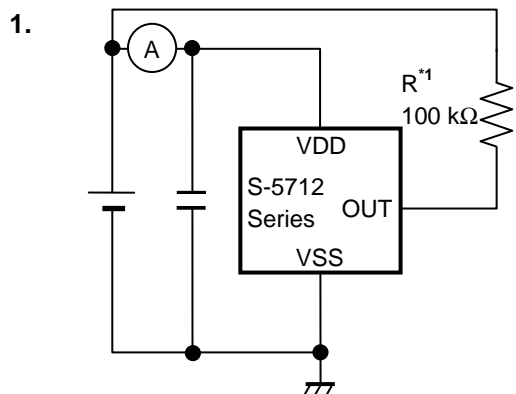

\*1. Resistor (R) is unnecessary for the CMOS output product.

Figure 6

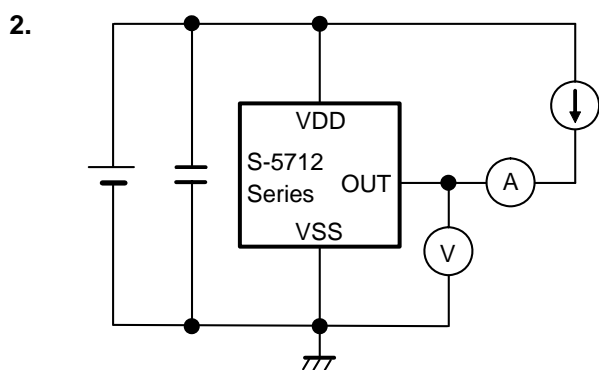

Figure 7

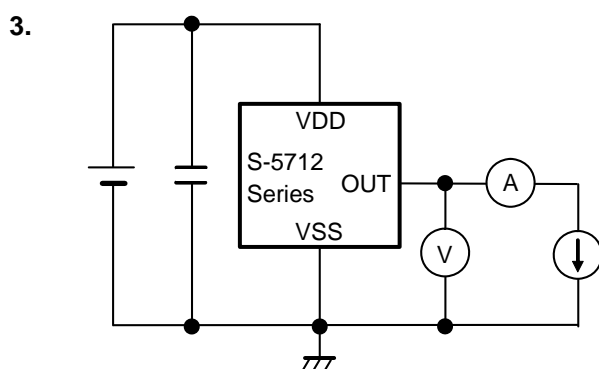

Figure 8

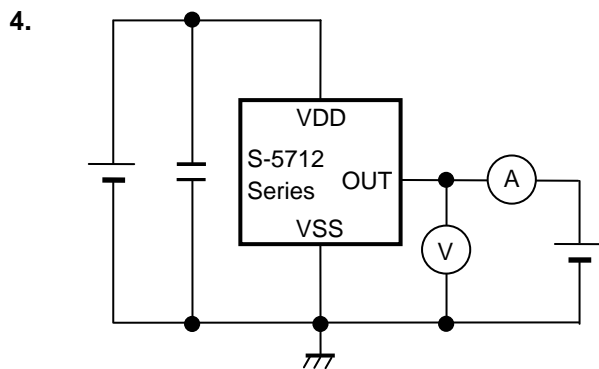
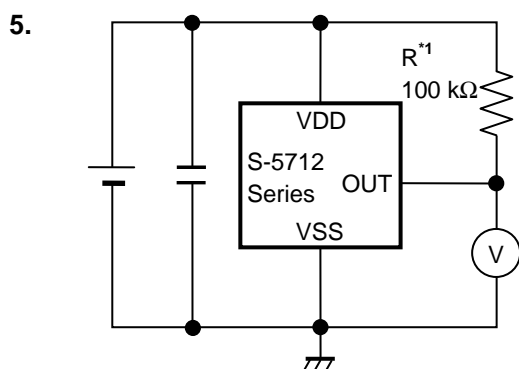

Figure 9



\*1. Resistor (R) is unnecessary for the CMOS output product.

Figure 10

■ Standard Circuit

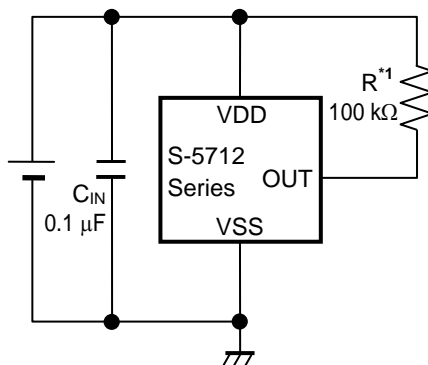

\*1. Resistor (R) is unnecessary for the CMOS output product.

Figure 11

**Caution** The above connection diagram and constant will not guarantee successful operation. Perform thorough evaluation using the actual application to set the constant.

■ Operation

1. Direction of applied magnetic flux

The S-5712 Series detects the flux density which is vertical to the marking surface.

In products with detection of both poles, the output voltage ( $V_{OUT}$ ) is inverted when the south or north pole is moved closer to the marking surface.

In products with detection of the south pole, the output voltage ( $V_{OUT}$ ) is inverted when the south pole is moved closer to the marking surface.

In products with detection of the north pole, the output voltage ( $V_{OUT}$ ) is inverted when the north pole is moved closer to the marking surface.

Figures 12 and 13 show the direction in which magnetic flux is being applied.

1.1 SOT-23-3

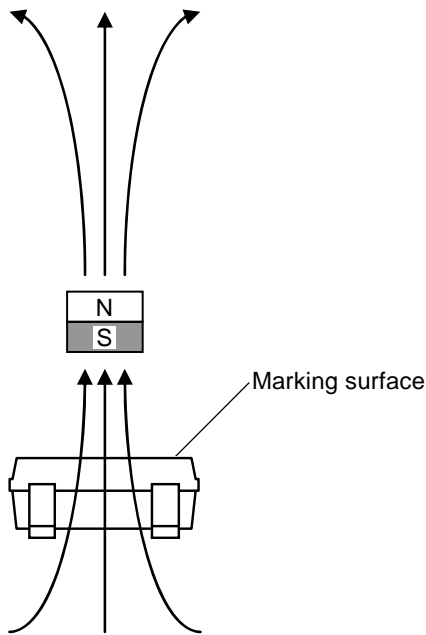

Figure 12

1.2 SNT-4A

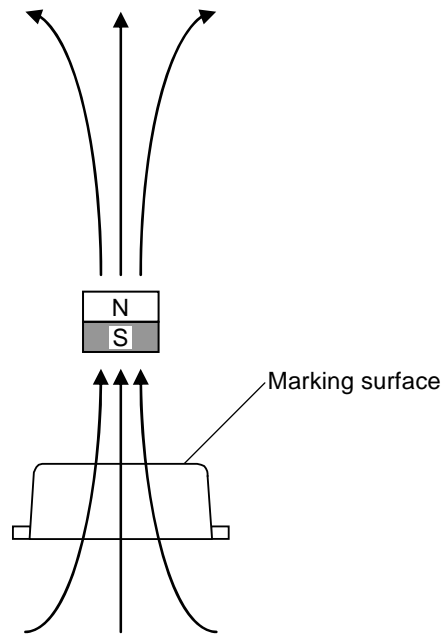

Figure 13

2. Position of Hall sensor

Figures 14 and 15 show the position of Hall sensor.

The center of this Hall sensor is located in the area indicated by a circle, which is in the center of a package as described below.

The following also shows the distance (typ. value) between the marking surface and the chip surface of a package.

2.1 SOT-23-3

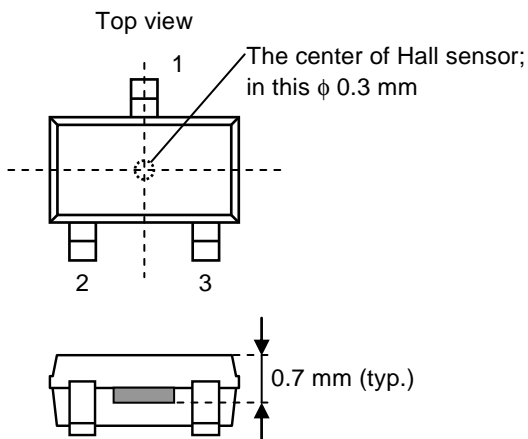

Figure 14

2.2 SNT-4A

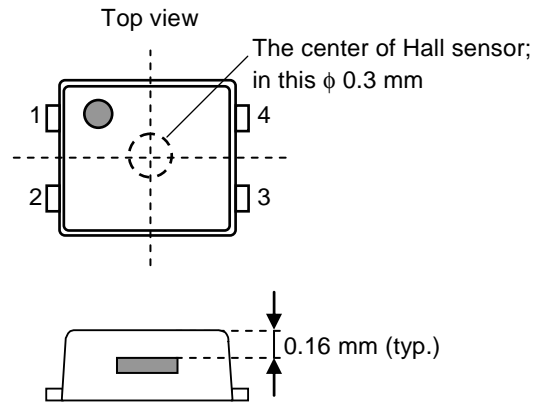

Figure 15

**3. Basic operation**

The S-5712 Series changes the output voltage level ( $V_{OUT}$ ) according to the level of the magnetic flux density (north or south pole) applied by a magnet.

The following explains the operation when the magnetism detection logic is active "L".

**3.1 Products with detection of both poles**

When the magnetic flux density vertical to the marking surface exceeds  $B_{OPN}$  or  $B_{OPS}$  after the south or north pole of a magnet is moved closer to the marking surface of the S-5712 Series,  $V_{OUT}$  changes from "H" to "L". When the south or north pole of a magnet is moved further away from the marking surface of the S-5712 Series and the magnetic flux density is lower than  $B_{RPN}$  or  $B_{RPS}$ ,  $V_{OUT}$  changes from "L" to "H".

**Figure 16** shows the relationship between the magnetic density and  $V_{OUT}$ .

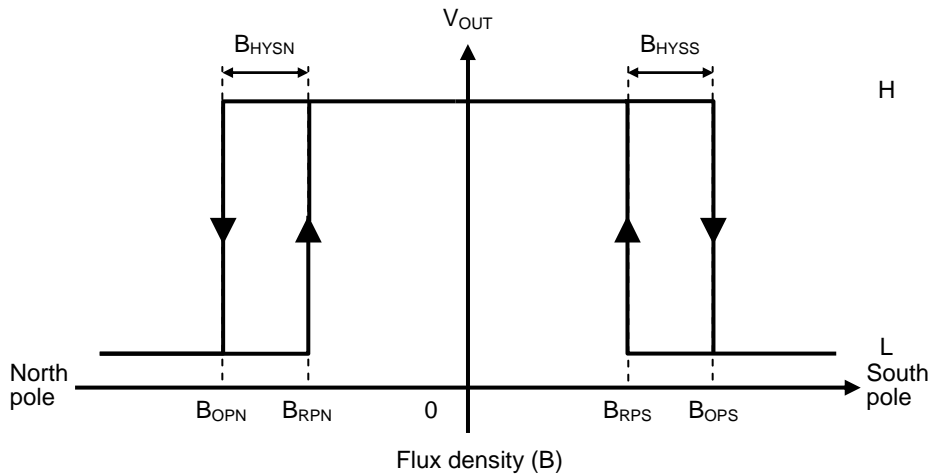
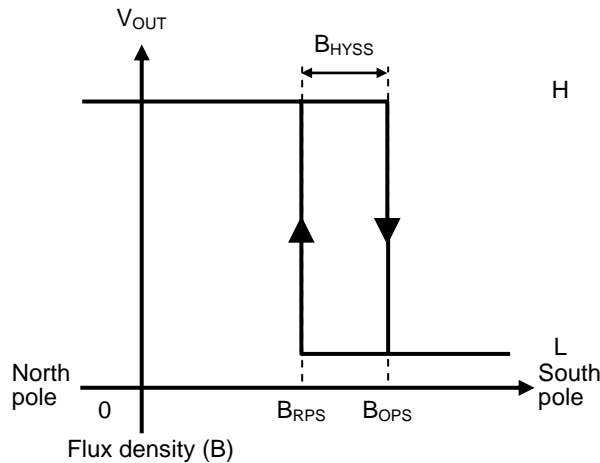

**Figure 16**

**3.2 Products with detection of south pole**

When the magnetic flux density vertical to the marking surface exceeds  $B_{OPS}$  after the south pole of a magnet is moved closer to the marking surface of the S-5712 Series,  $V_{OUT}$  changes from "H" to "L". When the south pole of a magnet is moved further away from the marking surface of the S-5712 Series and the magnetic flux density is lower than  $B_{RPS}$ ,  $V_{OUT}$  changes from "L" to "H".

**Figure 17** shows the relationship between the magnetic density and  $V_{OUT}$ .

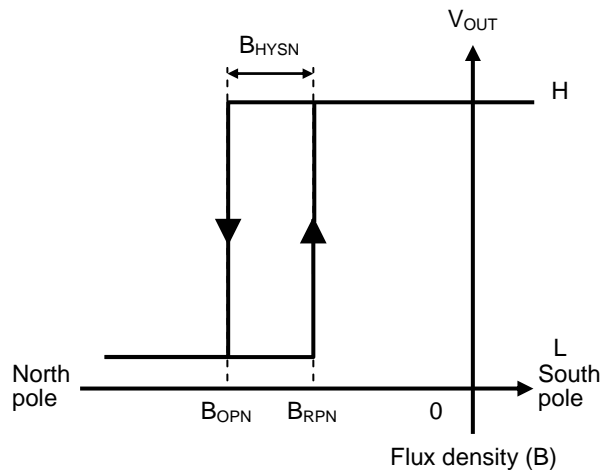

**Figure 17**

**3.3 Products with detection of north pole**

When the magnetic flux density vertical to the marking surface exceeds  $B_{OPN}$  after the north pole of a magnet is moved closer to the marking surface of the S-5712 Series,  $V_{OUT}$  changes from "H" to "L". When the north pole of a magnet is moved further away from the marking surface of the S-5712 Series and the magnetic flux density is lower than  $B_{RPN}$ ,  $V_{OUT}$  changes from "L" to "H".

**Figure 18** shows the relationship between the magnetic density and  $V_{OUT}$ .



**Figure 18**

■ **Precautions**

- If the impedance of the power supply is high, the IC may malfunction due to a supply voltage drop caused by through-type current. Take care with the pattern wiring to ensure that the impedance of the power supply is low.
- Note that the IC may malfunction if the power supply voltage rapidly changes.
- Do not apply an electrostatic discharge to this IC that exceeds the performance ratings of the built-in electrostatic protection circuit.
- Large stress on this IC may affect on the magnetic characteristics. Avoid large stress which is caused by bend and distortion during mounting the IC on a board or handle after mounting.
- SII claims no responsibility for any disputes arising out of or in connection with any infringement by products including this IC of patents owned by a third party.

## ■ Marking Specifications

### 1. SOT-23-3

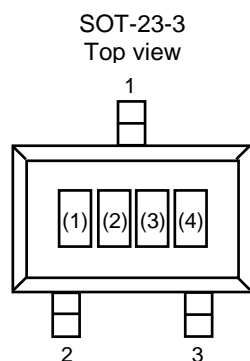

(1) to (3) : Product code (Refer to **Product name vs. Product code.**)  
 (4) : Lot number

#### Product name vs. Product code

##### 1.1 Nch open drain output product

Product Name	Product Code		
	(1)	(2)	(3)
S-5712ANDL1-M3T1U	X	A	B
S-5712ANDL2-M3T1U	X	A	C
S-5712ANSL1-M3T1U	X	A	J
S-5712ANSL2-M3T1U	X	A	K

##### 1.2 CMOS output product

Product Name	Product Code		
	(1)	(2)	(3)
S-5712ACDL1-M3T1U	X	B	B
S-5712ACDL2-M3T1U	X	B	C
S-5712ACDH1-M3T1U	X	B	F
S-5712ACDH2-M3T1U	X	B	G
S-5712ACSL1-M3T1U	X	B	J
S-5712ACSL2-M3T1U	X	B	K
S-5712ACNL1-M3T1U	X	B	R
S-5712ACNL2-M3T1U	X	B	S

**2. SNT-4A**

SNT-4A  
Top view

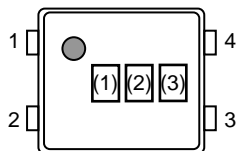

(1) to (3) : Product code (Refer to **Product name vs. Product code.**)

**Product name vs. Product code**

**2.1 Nch open drain output product**

Product Name	Product Code		
	(1)	(2)	(3)
S-5712ANDL1-I4T1U	X	A	B
S-5712ANDL2-I4T1U	X	A	C
S-5712ANSL1-I4T1U	X	A	J
S-5712ANSL2-I4T1U	X	A	K

**2.2 CMOS output product**

Product Name	Product Code		
	(1)	(2)	(3)
S-5712ACDL1-I4T1U	X	B	B
S-5712ACDL2-I4T1U	X	B	C
S-5712ACDH1-I4T1U	X	B	F
S-5712ACDH2-I4T1U	X	B	G
S-5712ACSL1-I4T1U	X	B	J
S-5712ACSL2-I4T1U	X	B	K
S-5712ACNL1-I4T1U	X	B	R
S-5712ACNL2-I4T1U	X	B	S

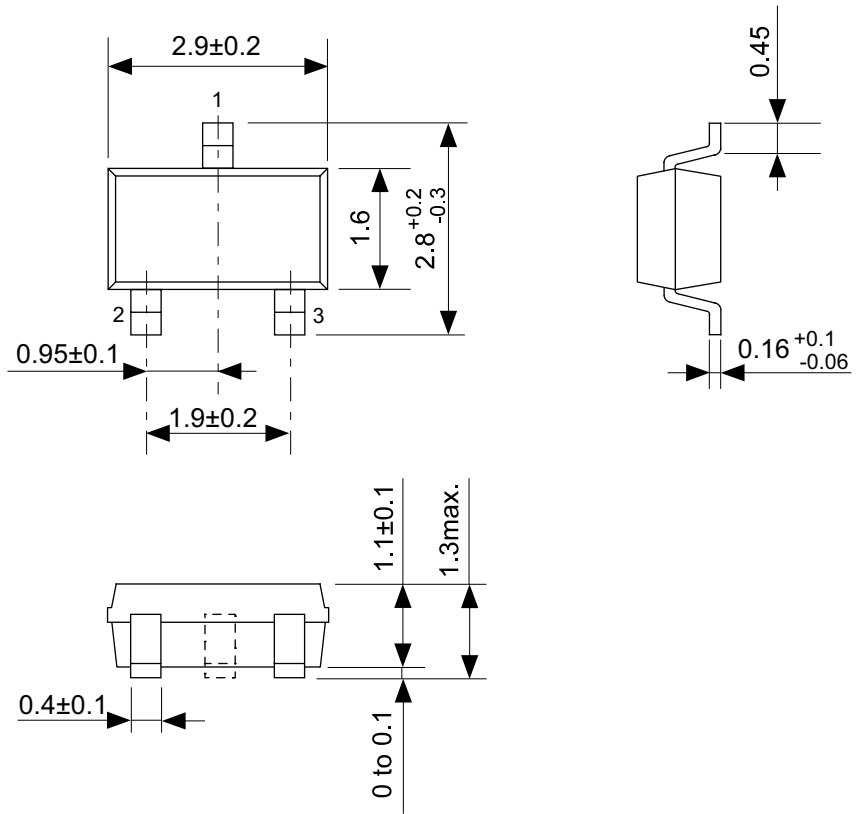

No. MP003-C-P-SD-1.0

TITLE	SOT233-C-PKG Dimensions
No.	MP003-C-P-SD-1.0
SCALE	
UNIT	mm
Seiko Instruments Inc.	

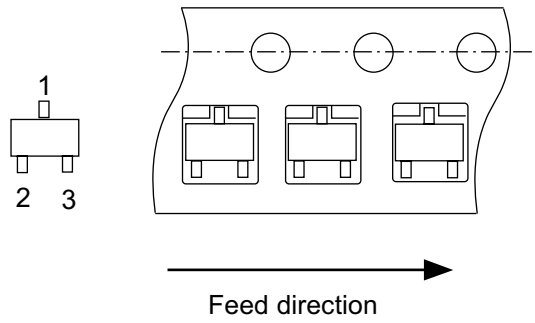
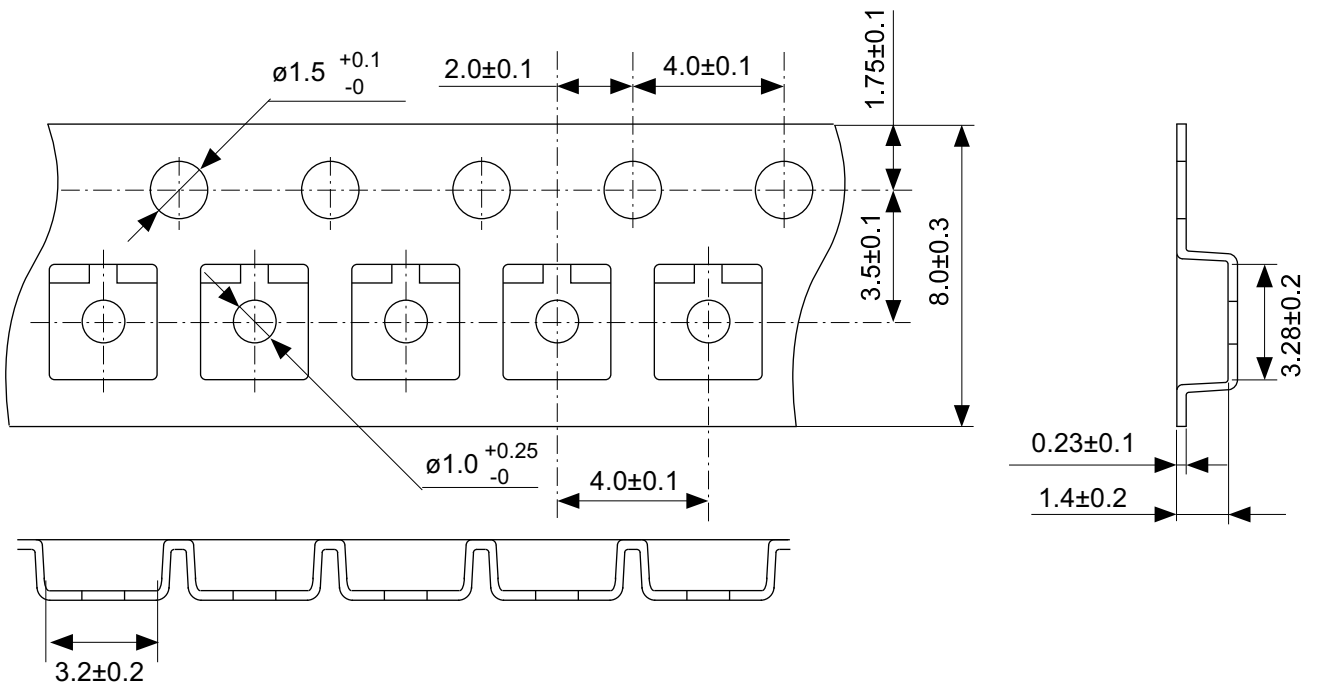

No. MP003-C-C-SD-2.0

TITLE	SOT233-C-Carrier Tape
No.	MP003-C-C-SD-2.0
SCALE	
UNIT	mm
Seiko Instruments Inc.	

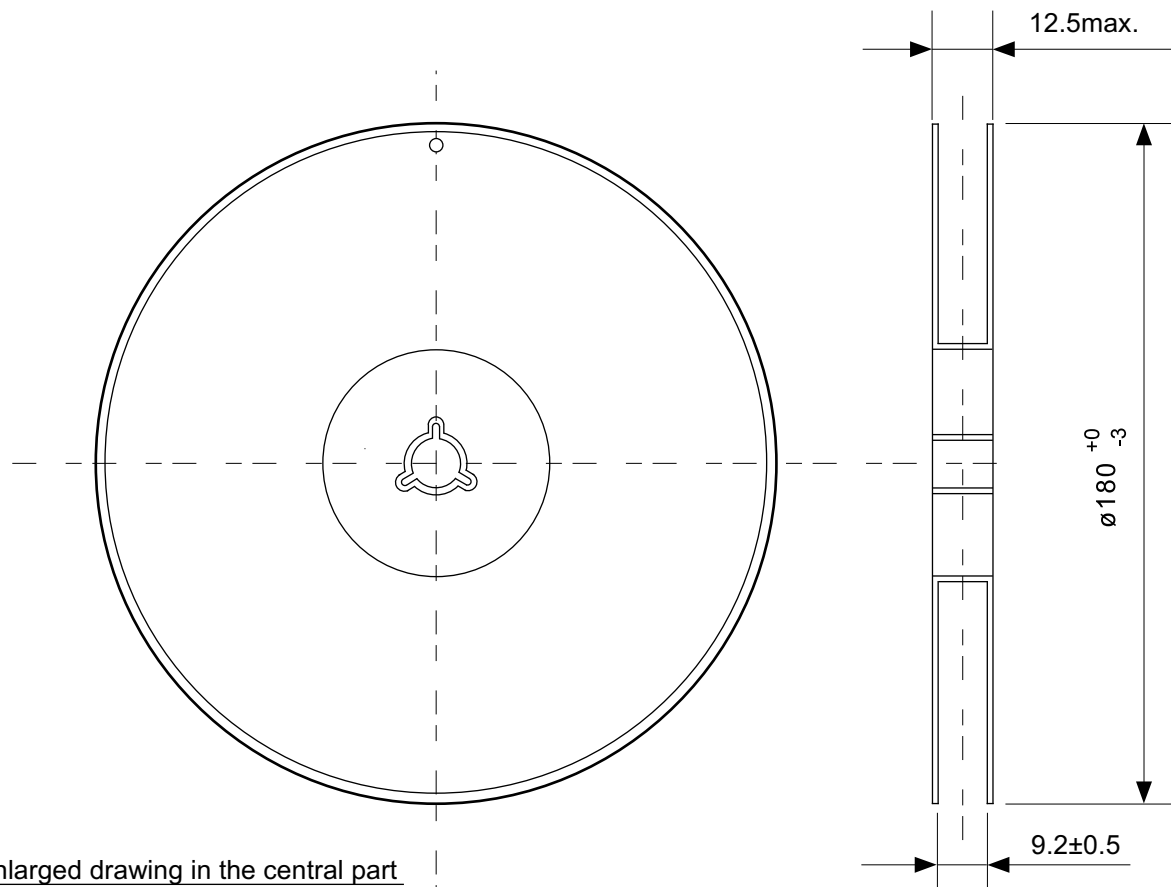

Enlarged drawing in the central part

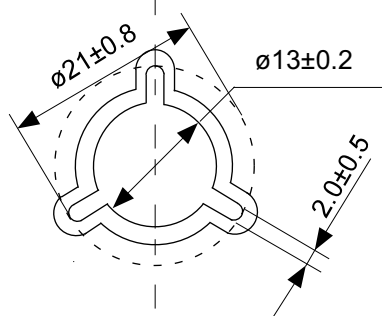

No. MP003-Z-R-SD-1.0

TITLE	SOT233-C-Reel		
No.	MP003-Z-R-SD-1.0		
SCALE		QTY.	3,000
UNIT	mm		

Seiko Instruments Inc.

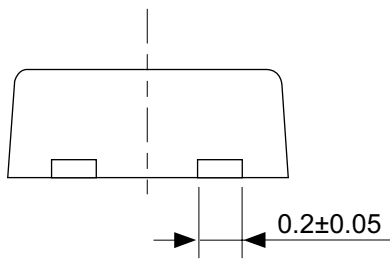
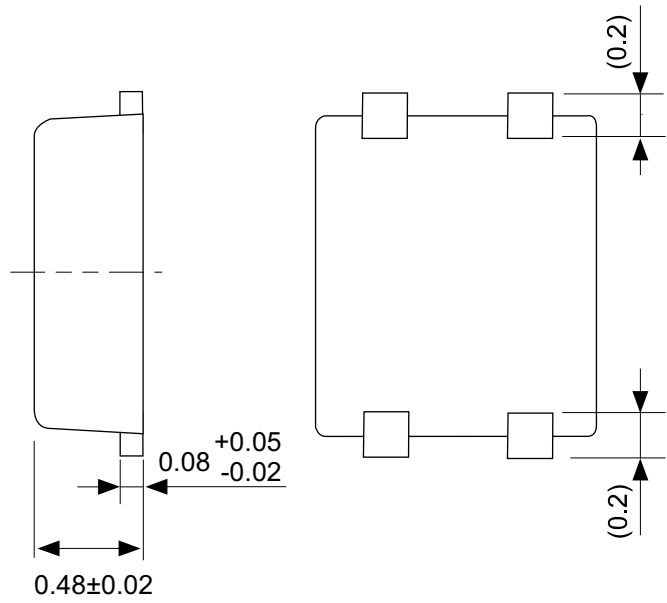
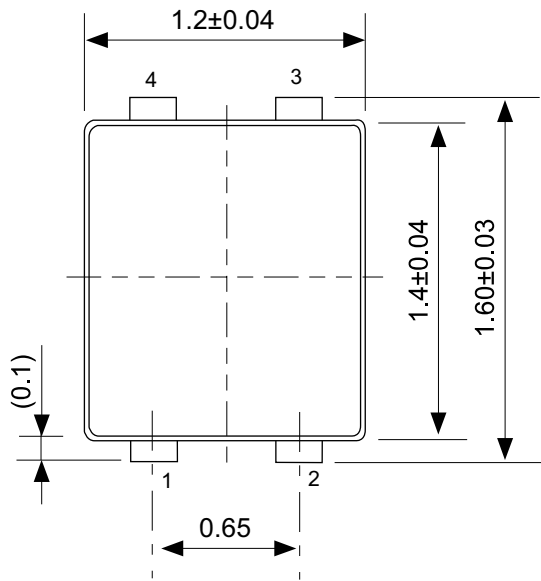

No. PF004-A-P-SD-4.0

TITLE	SNT-4A-A-PKG Dimensions
No.	PF004-A-P-SD-4.0
SCALE	
UNIT	mm
Seiko Instruments Inc.	

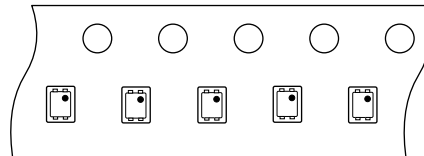
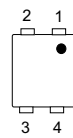
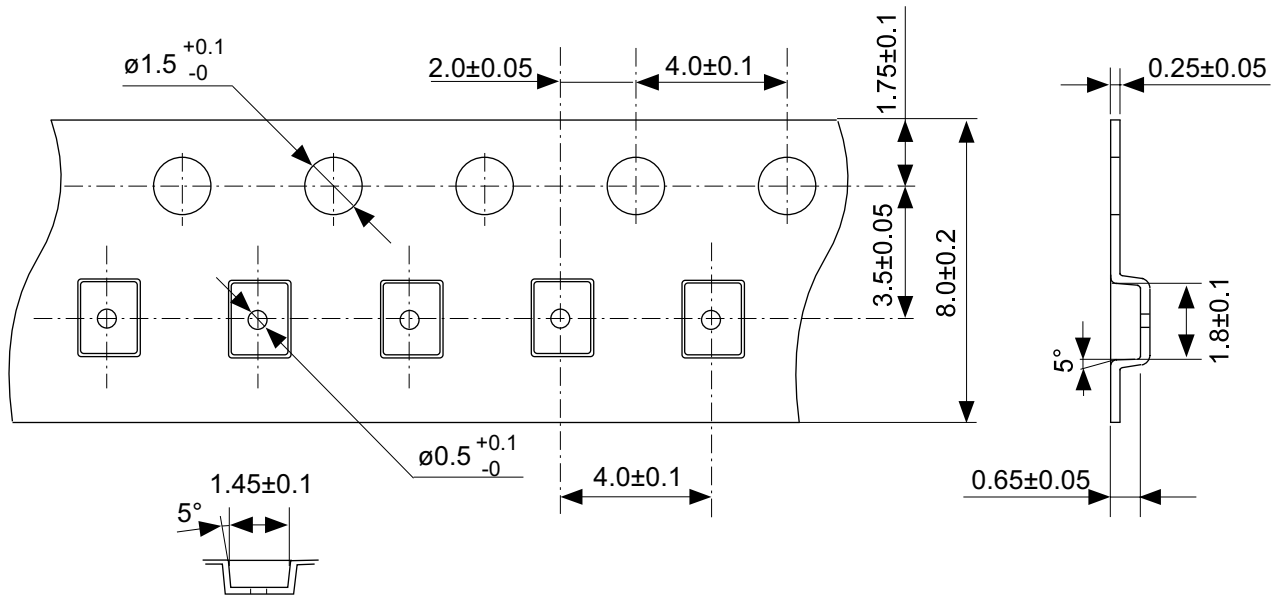

Feed direction

No. PF004-A-C-SD-1.0

TITLE	SNT-4A-A-Carrier Tape
No.	PF004-A-C-SD-1.0
SCALE	
UNIT	mm
Seiko Instruments Inc.	

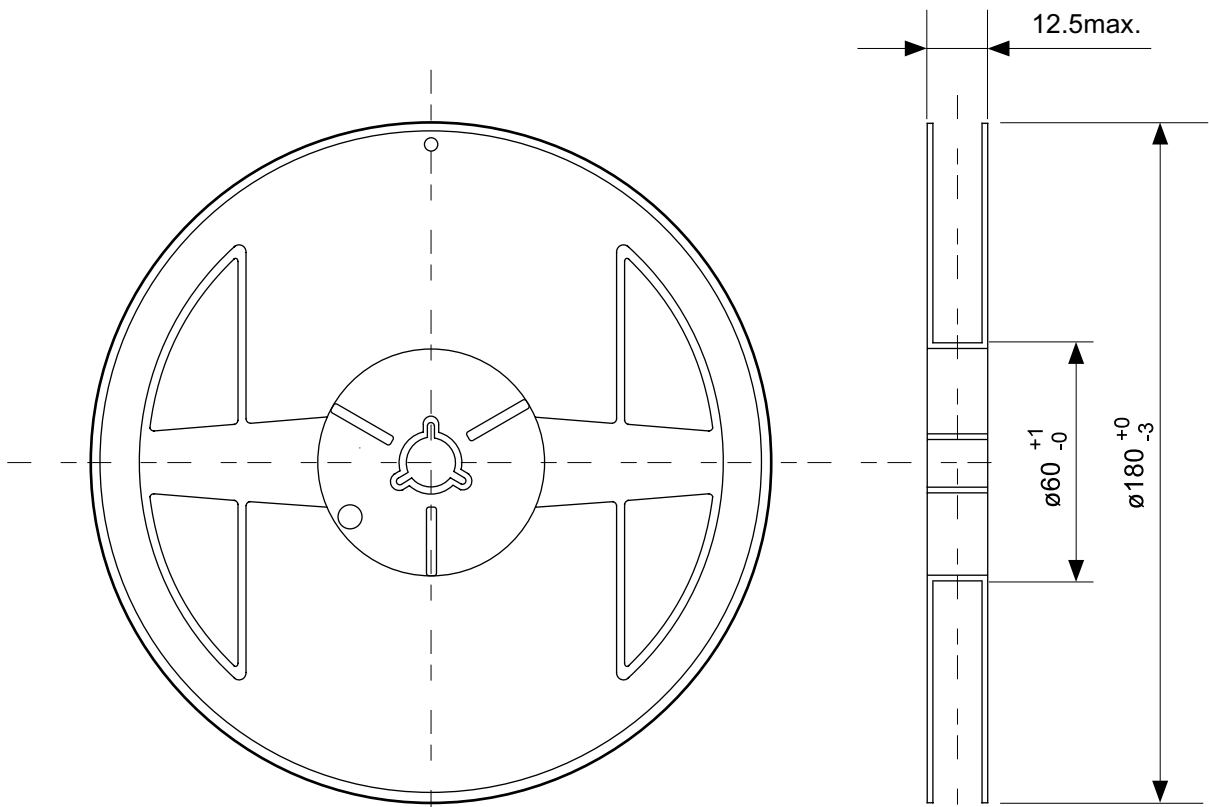

Enlarged drawing in the central part

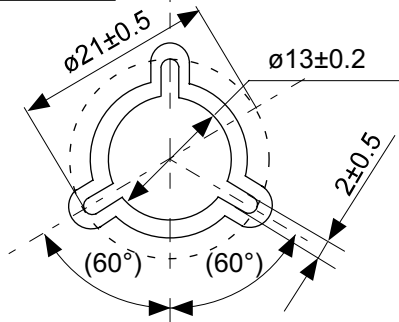

No. PF004-A-R-SD-1.0

TITLE	SNT-4A-A-Reel		
No.	PF004-A-R-SD-1.0		
SCALE		QTY.	5,000
UNIT	mm		
Seiko Instruments Inc.			

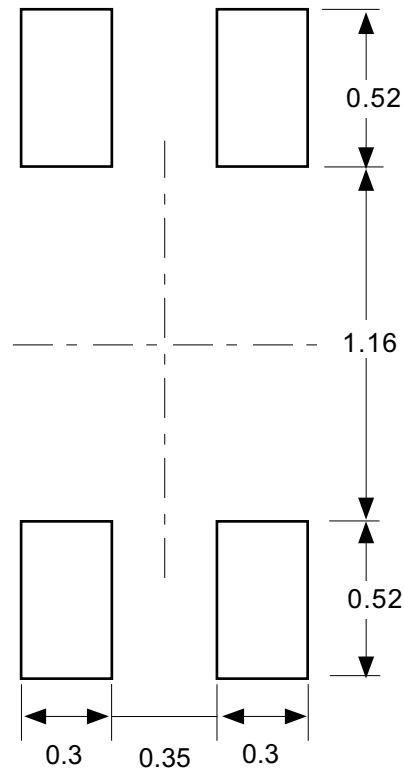

**Caution** Making the wire pattern under the package is possible. However, note that the package may be upraised due to the thickness made by the silk screen printing and of a solder resist on the pattern because this package does not have the standoff.

**注意** パッケージ下への配線パターン形成は可能ですが、本パッケージはスタンドオフが無いので、パターン上のレジスト厚み、シルク印刷の厚みによってパッケージが持ち上がる場合がありますのでご配慮ください。

No. PF004-A-L-SD-3.0

TITLE	SNT-4A-A-Land Recommendation
No.	PF004-A-L-SD-3.0
SCALE	
UNIT	mm
Seiko Instruments Inc.	



Seiko Instruments Inc.  
[www.sii-ic.com](http://www.sii-ic.com)

- The information described herein is subject to change without notice.
- Seiko Instruments Inc. is not responsible for any problems caused by circuits or diagrams described herein whose related industrial properties, patents, or other rights belong to third parties. The application circuit examples explain typical applications of the products, and do not guarantee the success of any specific mass-production design.
- When the products described herein are regulated products subject to the Wassenaar Arrangement or other agreements, they may not be exported without authorization from the appropriate governmental authority.
- Use of the information described herein for other purposes and/or reproduction or copying without the express permission of Seiko Instruments Inc. is strictly prohibited.
- The products described herein cannot be used as part of any device or equipment affecting the human body, such as exercise equipment, medical equipment, security systems, gas equipment, or any apparatus installed in airplanes and other vehicles, without prior written permission of Seiko Instruments Inc.
- Although Seiko Instruments Inc. exerts the greatest possible effort to ensure high quality and reliability, the failure or malfunction of semiconductor products may occur. The user of these products should therefore give thorough consideration to safety design, including redundancy, fire-prevention measures, and malfunction prevention, to prevent any accidents, fires, or community damage that may ensue.