

## 2-WIRE SERIAL E<sup>2</sup>PROM FOR DIMM SERIAL PRESENCE DETECT

[www.sii-ic.com](http://www.sii-ic.com)

© Seiko Instruments Inc., 2007-2011

Rev.5.0\_00

The S-34C02A is a 2-wire serial E<sup>2</sup>PROM for DIMM Serial Presence Detect which operates with low current consumption and the wide range operation. The S-34C02A has the capacity of 2K-bit and the organization of 256 words × 8-bit.

Page Write and Sequential Read are available.

The S-34C02A has Hardware Protect and Software Protect. Hardware Protect inhibits Write to all memory area by connecting the WP pin to V<sub>CC</sub>. Software Protect inhibits Write in 50% of the lower address (the address 00h to 7Fh) in all memory area by inputting command when the WP pin is connected to GND or left open.

### ■ Features

- Operating voltage range      Read:      1.6 V to 5.5 V  
   Write:      1.7 V to 5.5 V
- Page write:                      16 bytes / page
- Sequential read
- Operation frequency:        400 kHz (V<sub>CC</sub> = 2.5 V to 5.5 V)
- Write time:                      4.0 ms max.
- Noise suppression:         Schmitt trigger and noise filter on bus input pins (SCL, SDA)
- Write protect function during the low power supply voltage
- Endurance:                      10<sup>6</sup> cycles / word<sup>\*1</sup> (Ta = +25°C)
- Data retention:                100 years (Ta = +25°C)
- Memory capacity:              2 K-bit
- Write protect:                    Hardware Protect 100% (addresses 00h to FFh)  
   Software Protect for the lower address of 50% (addresses 00h to 7Fh)
- Initial shipment data:        FFh
- Lead-free, Sn 100%, halogen-free<sup>\*2</sup>

\*1. For each address (Word: 8-bit)

\*2. Refer to the “**■ Product Name Structure**” for the details.

### ■ Packages

- 8-Pin TSSOP
- PLP-8C

**Caution** This product is intended to use in general electronic devices such as consumer electronics, office equipment, and communications devices. Before using the product in medical equipment or automobile equipment including car audio, keyless entry and engine control unit, contact to SII is indispensable.

■ Pin Configurations

1. 8-Pin TSSOP

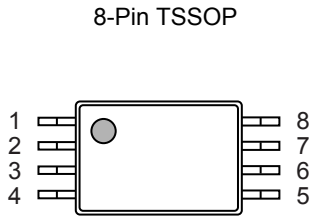

8-Pin TSSOP

Figure 1

S-34C02A0I-T8T1U

Table 1

Pin No.	Symbol	Description
1	A0	Slave address input
2	A1	Slave address input
3	A2	Slave address input
4	GND	Ground
5	SDA	Serial data I/O
6	SCL	Serial clock input
7	WP	Write protection input Connected to V <sub>CC</sub> : Protection valid Connected to GND: Protection invalid
8	VCC	Power supply

2. PLP-8C

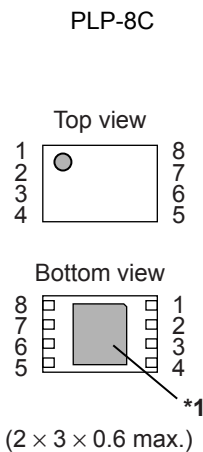

PLP-8C

Table 2

Pin No.	Symbol	Description
1	A0	Slave address input
2	A1	Slave address input
3	A2	Slave address input
4	GND	Ground
5	SDA	Serial data I/O
6	SCL	Serial clock input
7	WP	Write protection input Connected to V <sub>CC</sub> : Protection valid Connected to GND: Protection invalid
8	VCC	Power supply

- \*1. Connect the heatsink of backside at shadowed area to the board, and set electric potential open or GND. However, do not use it as the function of electrode.

Figure 2

S-34C02A0I-X8T3S

- Remark 1.** Refer to the “package drawings” for the details.  
2. Please select products of environmental code = U for Sn 100%, halogen-free products.

■ Block Diagram

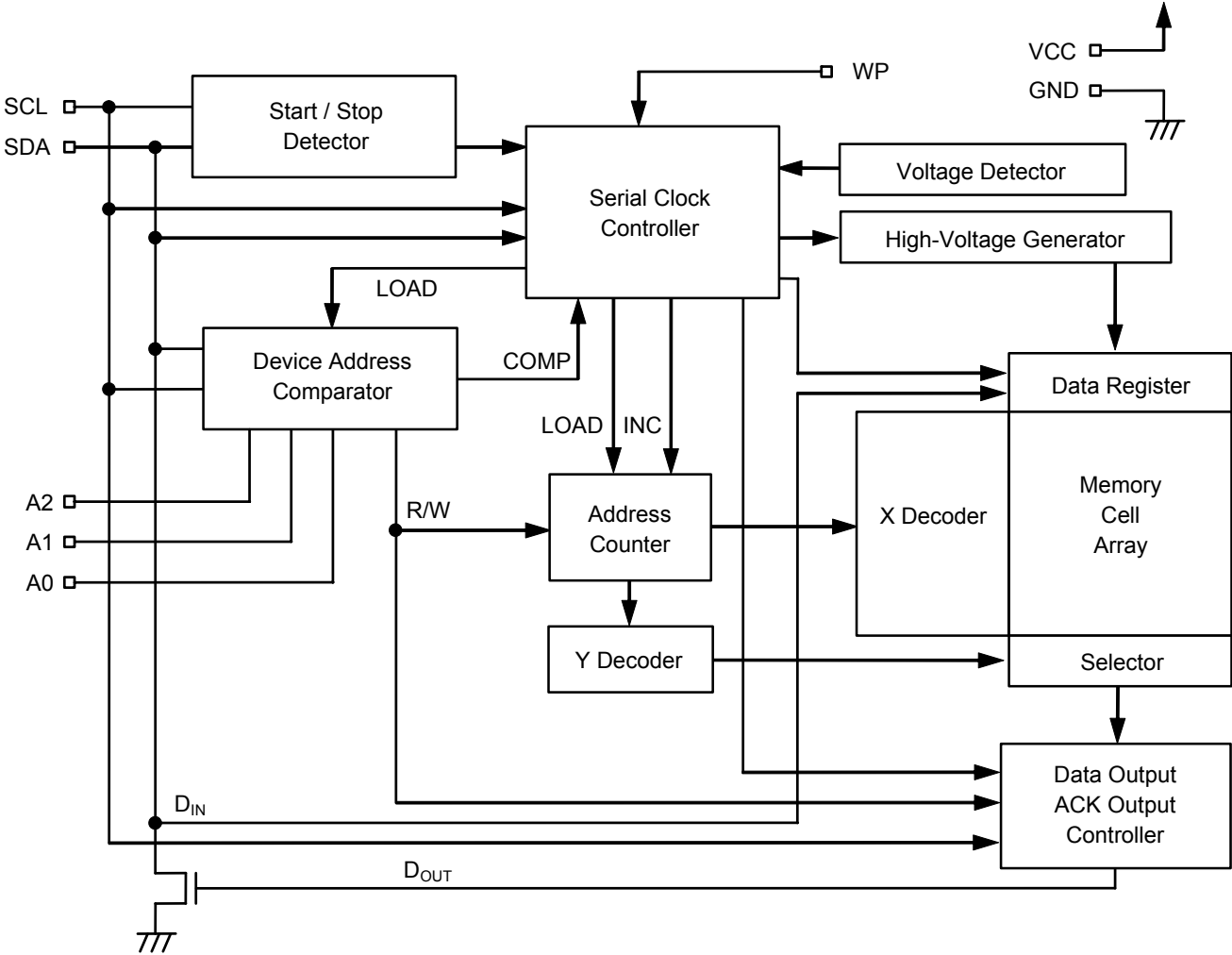

Figure 3

■ Absolute Maximum Ratings

Table 3

Item	Symbol	Absolute Maximum Rating	Unit
Power supply voltage	V <sub>CC</sub>	-0.3 to +7.0	V
Input voltage	V <sub>IN</sub>	-0.3 to +7.0	V
A0 high level input voltage	V <sub>HV</sub>	-0.3 to +10.0	V
Output voltage	V <sub>OUT</sub>	-0.3 to +7.0	V
Operation ambient temperature	T <sub>opr</sub>	-40 to +85	°C
Storage temperature	T <sub>sta</sub>	-65 to +150	°C

Caution The absolute maximum ratings are rated values exceeding which the product could suffer physical damage. These values must therefore not be exceeded under any conditions.

■ Recommended Operating Conditions

Table 4

Item	Symbol	Condition	Ta = -40°C to +85°C		Unit
			Min.	Max.	
Power supply voltage	V <sub>CC</sub>	Read Operation	1.6	5.5	V
		Write Operation	1.7	5.5	V
High level input voltage	V <sub>IH</sub>	V <sub>CC</sub> = 1.6 V to 5.5 V	0.7 × V <sub>CC</sub>	V <sub>CC</sub>	V
Low level input voltage	V <sub>IL</sub>	V <sub>CC</sub> = 1.6 V to 5.5 V	0.0	0.3 × V <sub>CC</sub>	V
A0 high level input voltage	V <sub>HV</sub>	V <sub>HV</sub> - V <sub>CC</sub> > 4.8 V	7.0	10.0	V

■ Pin Capacitance

Table 5

(Ta = +25°C, f = 1.0 MHz, V<sub>CC</sub> = 5.0 V)

Item	Symbol	Condition	Min.	Max.	Unit
Input capacitance	C <sub>IN</sub>	V <sub>IN</sub> = 0 V (SCL, A0, A1, A2, WP)	-	10	pF
I/O capacitance	C <sub>I/O</sub>	V <sub>I/O</sub> = 0 V (SDA)	-	10	pF

■ Endurance

Table 6

Item	Symbol	Operation Ambient Temperature	Min.	Max.	Unit
Endurance	N <sub>W</sub>	Ta = +25°C	10 <sup>6</sup>	-	cycles / word*1

\*1. For each address (Word: 8-bit)

■ Data Retention

Table 7

Item	Symbol	Operation Ambient Temperature	Min.	Max.	Unit
Data retention	-	Ta = +25°C	100	-	year

■ DC Electrical Characteristics

**Table 8**

Item	Symbol	Condition	Ta = -40°C to +85°C						Unit
			V <sub>CC</sub> = 2.5 V to 5.5 V f <sub>SCL</sub> = 400 kHz		V <sub>CC</sub> = 1.6 V to 2.5 V f <sub>SCL</sub> = 100 kHz		V <sub>CC</sub> = 1.7 V to 2.5 V f <sub>SCL</sub> = 100 kHz		
			Min.	Max.	Min.	Max.	Min.	Max.	
Current consumption (READ)	I <sub>CC1</sub>	–	–	0.8	–	0.2	–	0.2	mA
Current consumption (WRITE)	I <sub>CC2</sub>	–	–	4.0	–	–	–	1.5	mA

**Table 9**

Item	Symbol	Condition	Ta = -40°C to +85°C				Unit
			V <sub>CC</sub> = 2.5 V to 5.5 V		V <sub>CC</sub> = 1.6 V to 2.5 V		
			Min.	Max.	Min.	Max.	
Standby current consumption	I <sub>SB</sub>	V <sub>IN</sub> = V <sub>CC</sub> or GND	–	1.5	–	1.5	μA
Input leakage current	I <sub>LI</sub>	SCL, SDA V <sub>IN</sub> = GND to V <sub>CC</sub>	–	1.0	–	1.0	μA
Output leakage current	I <sub>LO</sub>	SDA V <sub>OUT</sub> = GND to V <sub>CC</sub>	–	1.0	–	1.0	μA
Input current 1	I <sub>IL</sub>	A0, A1, A2, WP V <sub>IN</sub> < 0.3 × V <sub>CC</sub>	–	50.0	–	50.0	μA
Input current 2	I <sub>IH</sub>	A0, A1, A2, WP V <sub>IN</sub> > 0.7 × V <sub>CC</sub>	–	2.0	–	2.0	μA
Input Impedance 1	Z <sub>IL</sub>	A0, A1, A2, WP V <sub>IN</sub> = 0.3 × V <sub>CC</sub>	30	–	30	–	kΩ
Input Impedance 2	Z <sub>IH</sub>	A0, A1, A2, WP V <sub>IN</sub> = 0.7 × V <sub>CC</sub>	800	–	800	–	kΩ
Low level output voltage	V <sub>OL</sub>	I <sub>OL</sub> = 3.2 mA	–	0.4	–	0.4	V
Current address hold voltage	V <sub>AH</sub>	–	1.5	5.5	1.5	2.5	V

■ AC Electrical Characteristics

Table 10 Measurement Conditions

Input pulse voltage	$0.1 \times V_{CC}$ to $0.9 \times V_{CC}$
Input pulse rising / falling time	20 ns
Output determination voltage	$0.5 \times V_{CC}$
Output load	100 pF + Pull-up resistor 1.0 kΩ

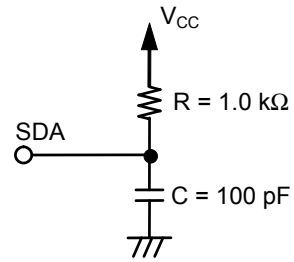

Figure 4 Output Load Circuit

Table 11

Item	Symbol	Ta = -40°C to +85°C				Unit
		V <sub>CC</sub> = 2.5 V to 5.5 V		V <sub>CC</sub> = 1.6 V to 2.5 V		
		Min.	Max.	Min.	Max.	
SCL clock frequency	f <sub>SCL</sub>	0	400	0	100	kHz
SCL clock time "L"	t <sub>LOW</sub>	1.3	–	4.7	–	μs
SCL clock time "H"	t <sub>HIGH</sub>	0.6	–	4.0	–	μs
SDA output delay time	t <sub>AA</sub>	0.1	0.9	0.1	3.5	μs
SDA output hold time	t <sub>DH</sub>	50	–	100	–	ns
Start condition setup time	t <sub>SU.STA</sub>	0.6	–	4.7	–	μs
Start condition hold time	t <sub>HD.STA</sub>	0.6	–	4.0	–	μs
Data input setup time	t <sub>SU.DAT</sub>	100	–	200	–	ns
Data input hold time	t <sub>HD.DAT</sub>	0	–	0	–	ns
Stop condition setup time	t <sub>SU.STO</sub>	0.6	–	4.0	–	μs
SCL, SDA rising time	t <sub>R</sub>	–	0.3	–	1.0	μs
SCL, SDA falling time	t <sub>F</sub>	–	0.3	–	0.3	μs
WP setup time	t <sub>WS1</sub>	0	–	0	–	μs
WP hold time	t <sub>WH1</sub>	0	–	0	–	μs
WP release setup time	t <sub>WS2</sub>	0	–	0	–	μs
WP release hold time	t <sub>WH2</sub>	0	–	0	–	μs
Bus release time	t <sub>BUF</sub>	1.3	–	4.7	–	μs
Noise suppression time	t <sub>I</sub>	–	50	–	100	ns

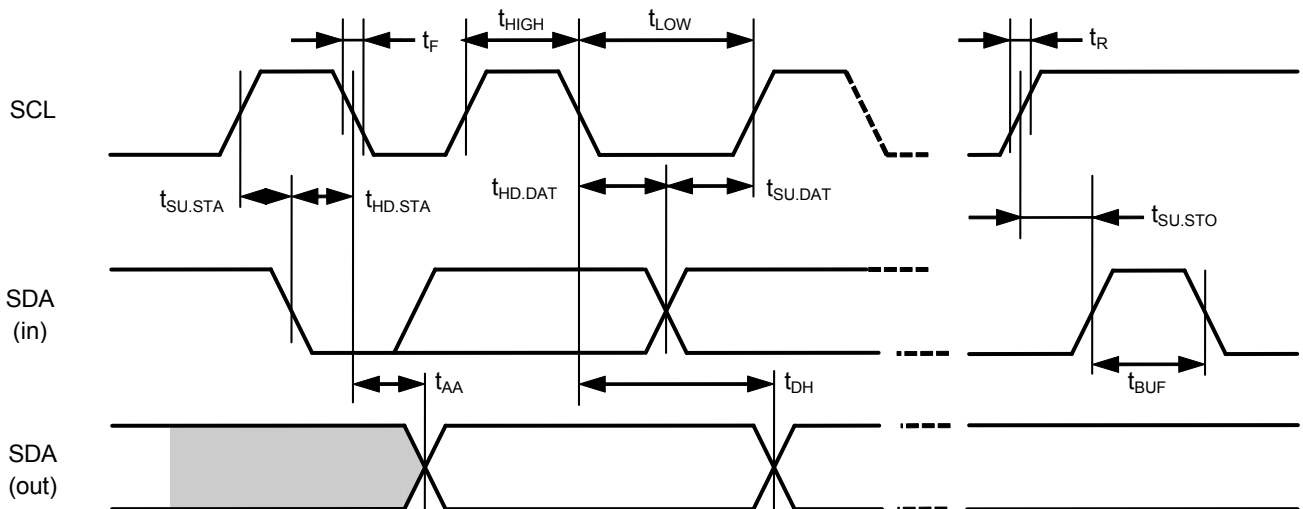

Figure 5 Bus Timing

Table 12

Item	Symbol	Ta = -40°C to +85°C		Unit
		V <sub>CC</sub> = 1.7 V to 5.5 V		
		Min.	Max.	
Write time	t <sub>WR</sub>	-	4.0	ms

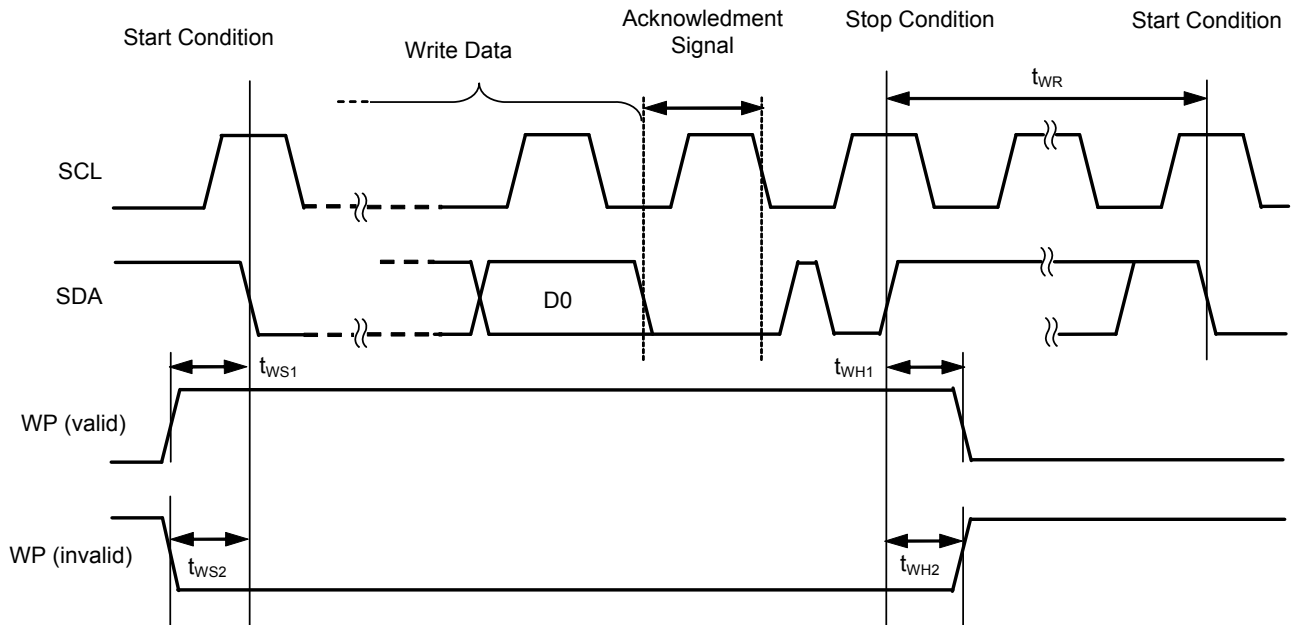

Figure 6 Write Cycle Timing

## ■ Pin Functions

### 1. A0, A1 and A2 (Slave Address Input) pins

In the S-34C02A, to set the slave address, connect each pin of A0, A1, A2 to GND or V<sub>CC</sub>. Therefore the users can set 8 types of slave address by a combination of A0, A1, A2 pins.

Comparing the slave address transmitted from the master device and one that you set, makes possible to select the S-34C02A from other devices connected onto the bus.

Be sure to connect to fix the address input pin to GND or V<sub>CC</sub>.

### 2. SDA (Serial Data Input / Output) pin

The SDA pin is used for the bi-directional transmission of serial data. It consists of a signal input pin and an Nch open drain output pin.

In use, generally, connect the SDA line to any other device which has the open-drain or open-collector output with Wired-OR connection by pulling up to V<sub>CC</sub> by a resistor.

### 3. SCL (Serial Clock Input) pin

The SCL pin is used for the serial clock input. Since the signals are processed at a rising or falling edge of the SCL clock, pay attention to the rising and falling time and comply with the specification.

### 4. WP (Write Protect) pin

The Write protect function is to inhibit Write in all memory area or in the protect register while this pin is being connected to V<sub>CC</sub>. While the WP pin is being connected to GND or left open, this pin inhibits Write in the first half of memory (addresses 00h to 7Fh) according to the status of the protect register.

## ■ Initial Shipment Data

Initial shipment data of all addresses is "FFh".

■ **Operation**

**1. Start condition**

A start condition starts by changing the SDA line from “H” to “L” while the SCL line is “H”. All operations start with a start condition.

**2. Stop condition**

A stop condition starts by changing the SDA line from “L” to “H” while the SCL line is “H”. During Read sequence if the S-34C02A receives a stop condition, its Read operation is interrupted so that the S-34C02A goes in the standby mode. During Write sequence if the S-34C02A receives a stop condition, the S-34C02A finishes installing Write data so that the Write operation starts.

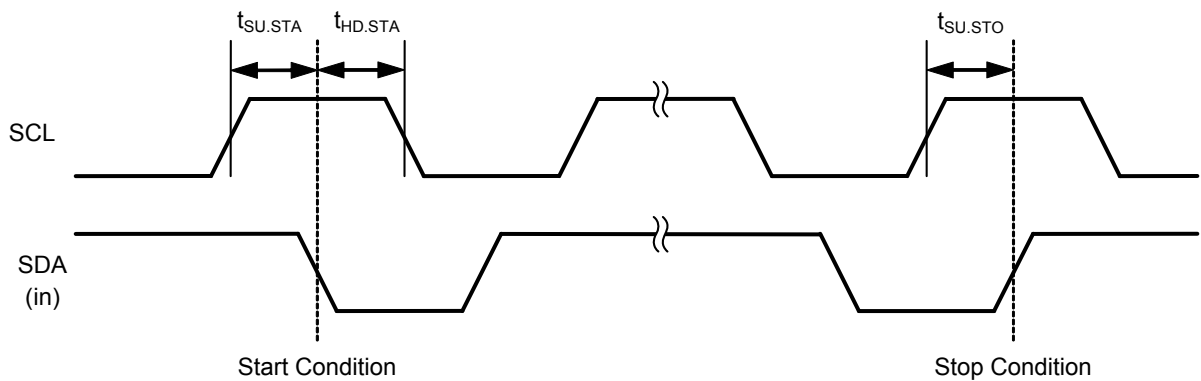
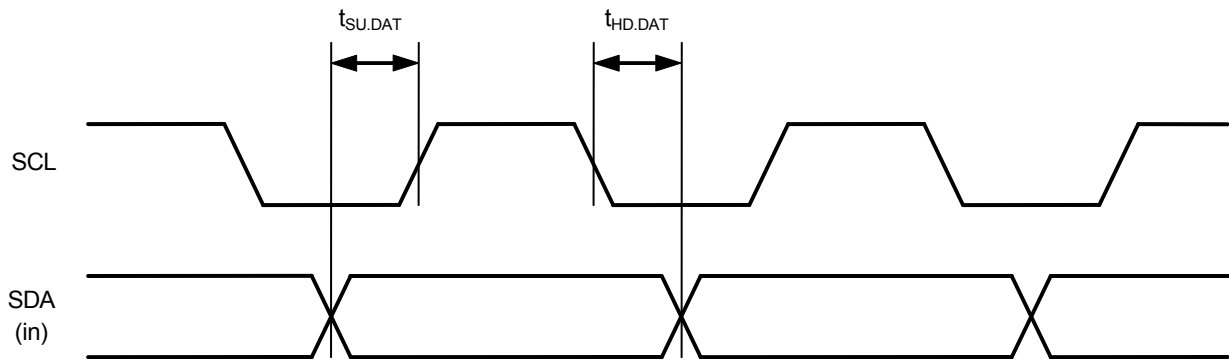

**Figure 7 Start / Stop Conditions**

**3. Data transmission**

Data is transmitted by changing the SDA line while the SCL line is "L".

If the SDA line changes while the SCL line is "H", the S-34C02A goes in the start or stop condition status.

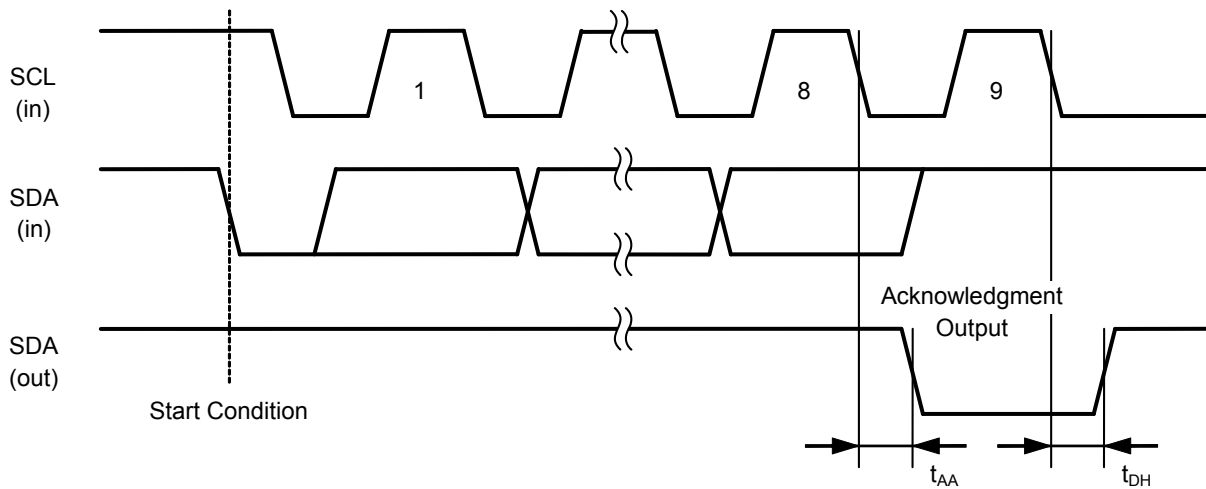

**Figure 8 Data Transmission Timing**

**4. Acknowledgment**

Data is transmitted sequentially in 8-bit. Changing the SDA line to "L" indicates that the devices on the system bus have received data, thus the devices send an acknowledgment signal back during the 9th clock of cycle.

The S-34C02A does not send an acknowledgment signal back during the Write operation.



**Figure 9 Acknowledgment Output Timing**

**5. Device addressing**

To start the transmission, the master device on the system generates a start condition for the slave address. After that, the master device transmits the 7-bit device address and the 1-bit Read / Write instruction code to the SDA bus.

In the S-34C02A, the higher 4 bits of the device address are device code, and are fixed at "1010".

The next 3 bits of the device address are slave address. This address is used to select the devices on the system bus, and is compared with the address value which is set beforehand by the address input pins (A0, A1, A2). If the comparison result matches, the slave address sends an acknowledgment signal back at the 9th clock of cycle.

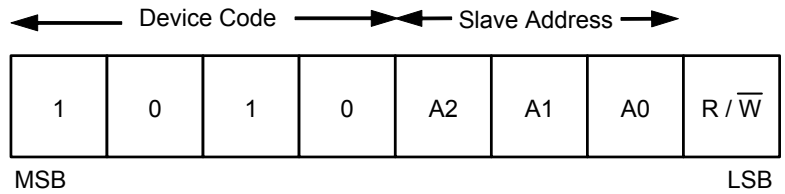

**Figure 10 Device Address**

**6. Write operation**

**6.1 Byte write**

When the S-34C02A receives the 7-bit device address and the Read / Write instruction code "0" after receiving a start condition, it generates an acknowledgment signal.

Next, it receives the 8-bit word address, and generates an acknowledgment signal. After that, it receives 8-bit Write data and generates an acknowledgment signal, it receives a stop condition so that the Write operation to the specified memory address starts.

During the Write operation to the S-34C02A, all operations are inhibited to be performed and the S-34C02A does not send back an acknowledgment signal.

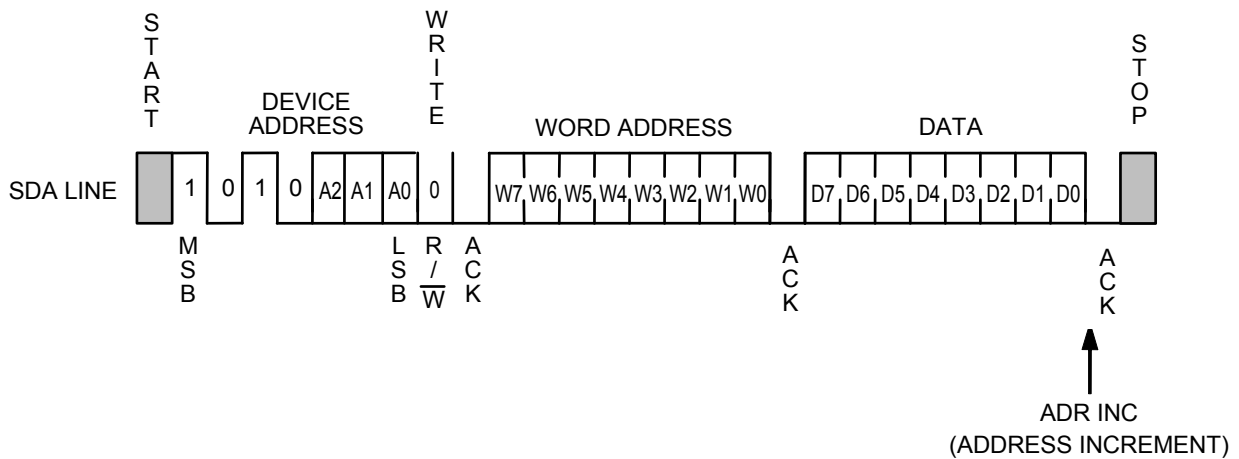

**Figure 11 Byte Write**

**6.2 Page write**

The page write mode allows up to 16 bytes to be written in a single write operation in the S-34C02A.

Its basic process to transmit data is as same as byte write, but it operates page write by sequentially receiving 8-bit write data as much data as the page size has.

When the S-34C02A receives a 7-bit device address and a 1-bit read / write instruction code set to "0", following a start condition, it generates an acknowledge. And the S-34C02A receives 8-bit word address and responds with an acknowledge. After the S-34C02A receives 8-bit write data and responds with an acknowledge, it receives 8-bit write data corresponding to the next word address, and generates an acknowledge. The S-34C02A repeats reception of 8-bit write data and generation of acknowledge in succession. The S-34C02A can receive as many write data as the maximum page size.

Receiving a stop condition initiates a write cycle of the area starting from the designated memory address and having the page size equal to the received write data.

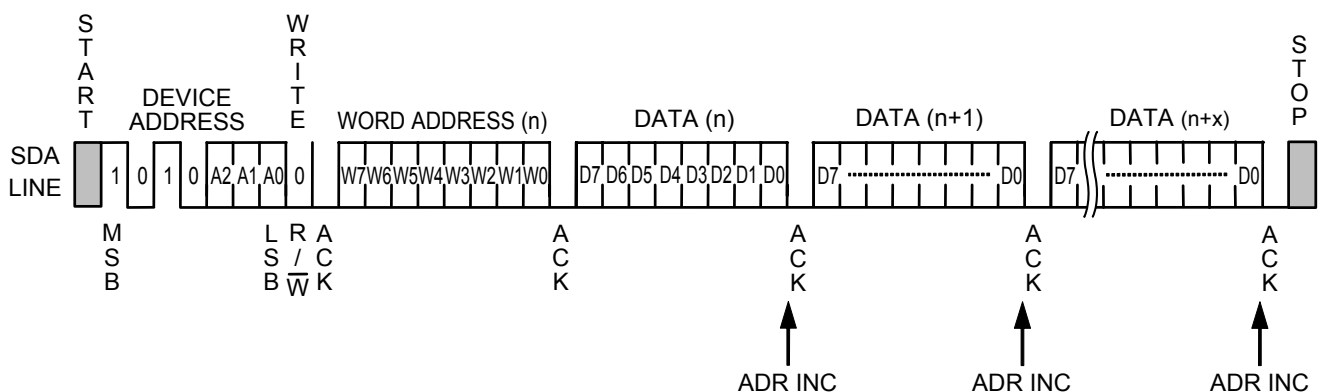

**Figure 12 Page Write**

In the S-34C02A, the lower 4 bits of the word address are automatically incremented every time when the S-34C02A receives 8-bit write data. If the size of the write data exceeds 16 bytes, the upper 4 bits of the word address remain unchanged, and the lower 4 bits are rolled over and the write data will be overwritten.

**6.3 Hardware write protect**

Write protect is available in the S-34C02A.

When the WP pin is connected to V<sub>CC</sub>, the Write operation in all memory area is inhibited.

Fix the WP pin during the period from the start condition to the stop condition in the Write operation (Byte Write and Page Write). Written data in the address is not assured if the condition of the WP pin is changed during this period. Refer to **Figure 6** regarding the timing of Hardware Write Protect.

Be sure to connect the WP pin to GND when you don't use Hardware Write Protect. Hardware Write Protect is valid in the range of power supply voltage. If setting Hardware Write Protect valid, the S-34C02A does not generate an acknowledgment signal.

In this case, the users cannot perform the SWP (Set RSWP), CWP (Clear RSWP), PSWP (Set PSWP) instructions.

**6.4 Software write protect**

The S-34C02A has Permanent Software Write Protect (PSWP) and Reversible Software Write Protect (RSWP).

**6.4.1 PSWP**

If the software protect has been set with the PSWP instruction, 50% of the lower address (addresses 00h to 7Fh) in all memory is permanently Write-protected. This Write protect cannot be cleared by any instruction, or by power-cycling the device, and regardless the state of WP pin. Also, once the PSWP instruction has been successfully executed, the S-34C02A no longer acknowledges any instruction (device code of "0110") to access the Write protect setting.

**6.4.2 RSWP**

If the software protect has been set with the SWP (Set RSWP) instruction, 50% of the lower address (addresses 00h to 7Fh) in all memory is Write-protected. This write protect can be cleared with the CWP (Clear RSWP) instruction.

These two instructions have the same format as a Byte Write instruction, but have a different device code. Like the Byte Write instruction, it is followed by an address byte and a data byte, but in this case the contents can be set in all "Don't Care". In the instructions of SWP and CWP, be sure to apply the high voltage of V<sub>HV</sub> to the A0 pin, and input "H" or "L" to the A1 and A2 pins.

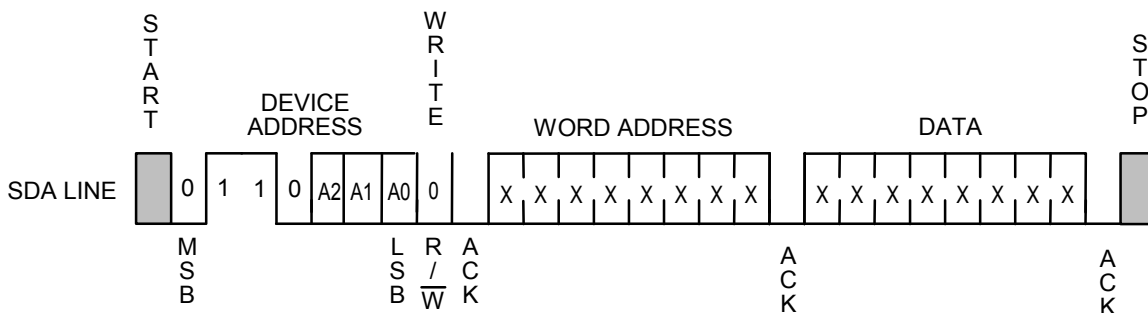

**Remark** X : Don't care

**Figure 13 Software Write Protect**

**Table 13 Device Select Code**

Instruction	Device Code				Slave Address			R/ $\bar{W}$	Pin Condition		
	B7	B6	B5	B4	B3	B2	B1	B0	A2	A1	A0
Memory area select <sup>*1</sup>	1	0	1	0	A2	A1	A0	R/ $\bar{W}$	A2	A1	A0
Set RSWP (SWP)	0	1	1	0	0	0	1	0	V <sub>SS</sub>	V <sub>SS</sub>	V <sub>HV</sub>
Clear RSWP (CWP)	0	1	1	0	0	1	1	0	V <sub>SS</sub>	V <sub>CC</sub>	V <sub>HV</sub>
Set PSWP (PSWP) <sup>*1</sup>	0	1	1	0	A2	A1	A0	0	A2	A1	A0
Read SWP	0	1	1	0	0	0	1	1	V <sub>SS</sub>	V <sub>SS</sub>	V <sub>HV</sub>
Read CWP	0	1	1	0	0	1	1	1	V <sub>SS</sub>	V <sub>CC</sub>	V <sub>HV</sub>
Read PSWP <sup>*1</sup>	0	1	1	0	A2	A1	A0	1	A2	A1	A0

\*1. Slave addresses A2, A1, A0 are compared by the address input pins (A0, A1, A2) of a memory device with the address value which is set beforehand.

**Table 14 Acknowledgment for WRITE Instruction ( $\overline{R/W}$  bit = 0)**

Status	WP	Instruction	ACK Output	Word Address	ACK Output	Data	ACK Output	Write
Permanent Software Write Protect (PSWP)	X	SWP, CWP or PSWP	No	Don't care	No	Don't care	No	No
		Page or Byte Write in Lower 128 bytes	Yes	Address	Yes	Data	No	No
Reversible Software Write Protect (RSWP)	0	SWP	No	Don't care	No	Don't care	No	No
		CWP	Yes	Don't care	Yes	Don't care	Yes	Yes
		PSWP	Yes	Don't care	Yes	Don't care	Yes	Yes
		Page or Byte Write in Lower 128 bytes	Yes	Address	Yes	Data	No	No
	1	SWP	No	Don't care	No	Don't care	No	No
		CWP	Yes	Don't care	Yes	Don't care	No	No
		PSWP	Yes	Don't care	Yes	Don't care	No	No
		Page or Byte Write	Yes	Address	Yes	Data	No	No
No software protect	0	SWP, CWP or PSWP	Yes	Don't care	Yes	Don't care	Yes	Yes
		Page or Byte Write	Yes	Address	Yes	Data	Yes	Yes
	1	SWP, CWP or PSWP	Yes	Don't care	Yes	Don't care	No	No
		Page or Byte Write	Yes	Address	Yes	Data	No	No

**Table 15 Acknowledgment for READ Instruction ( $\overline{R/W}$  bit = 1)**

Status	Instruction	ACK Output	Word Address	ACK Output	Data	ACK Output
Permanent Software Write Protect (PSWP)	SWP, CWP or PSWP	No	Don't care	No	Don't care	No
Reversible Software Write Protect (RSWP)	SWP	No	Don't care	No	Don't care	No
	CWP	Yes	Don't care	No	Don't care	No
	PSWP	Yes	Don't care	No	Don't care	No
No software protect	SWP, CWP or PSWP	Yes	Don't care	No	Don't care	No

### **6. 5 Acknowledge polling**

Acknowledge polling is used to find when the Write operation has completed. After receiving a stop condition the Write operation has once started, all operations are inhibited to be performed so that the S-34C02A cannot respond to the signals transmitted from the master device. The master device sends a start condition, the device address and Read / Write instruction code to the S-34C02A (slave address), and detects the response from the slave address. It is possible to find when the Write operation has completed. Thus if the slave device does not send an acknowledgment signal back, the Write operation is in progress. If it sends an acknowledgment signal back, the Write operation has completed. Fix the WP pin until an acknowledgment is confirmed. It is recommended to use the Read instruction "1" for the Read / Write instruction code transmitted by the master device during acknowledgment polling.

**7. Read**

**7.1 Current address read**

Both in the Write and Read operation, the S-34C02A maintains the memory address that is one the S-34C02A received when it has accessed last time. The memory address is maintained unless the power supply voltage is equal to the current address hold voltage  $V_{AH}$  or less. Therefore as long as the master device acknowledges the position where the address pointer is, data can be read by the memory address of an address pointer without specifying the word address. This is the current address Read.

The following is about the case that an address counter in the S-34C02A is in "n".

When the S-34C02A receives the 7-bit device address and the Read / Write instruction code "1" after receiving a start condition, it generates an acknowledgment signal.

Next, 8-bit data at address n is input from the S-34C02A synchronizing with a SCL clock. At the same time an address counter is incremented at a falling edge of SCL clock right after the output of 8th bit data, so that address n + 1 is contained in an address counter. The Read operation ends when the master device outputs a stop condition, not an acknowledgment signal.

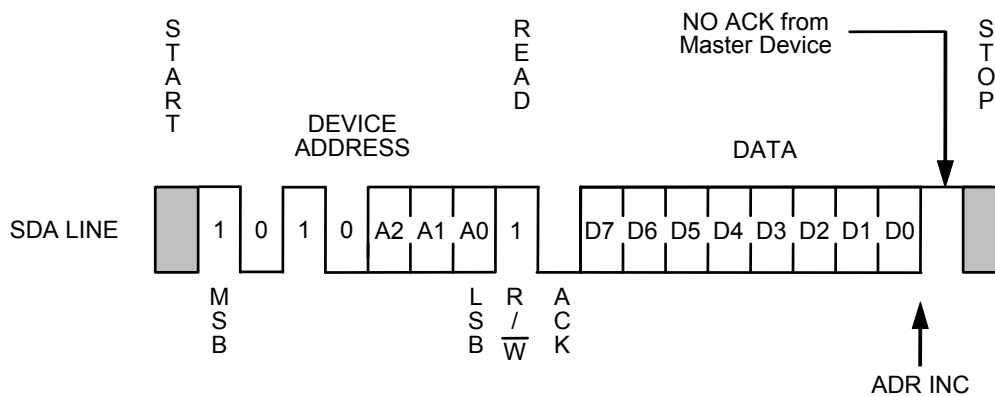

**Figure 14 Current Address Read**

Regarding the recognition of address pointer, pay attention to the following;

In the Read operation, a memory address counter in the S-34C02A is automatically incremented every time at a falling edge of the SCL clock right after the output of 8th bit data. However, in the Write operation, a memory address counter is not incremented because the higher 4 bits of the memory address (the higher 4 bits of the word address) are fixed every time at a falling edge of the SCL clock right after the receipt of 8th bit data.

**7.2 Random read**

Random Read is used to read data at an arbitrary memory address.

To load the memory address into an address counter in the S-34C02A, perform Dummy Write with the process below.

When the S-34C02A receives the 7-bit device address and the Read / Write instruction code "0" after receiving a start condition, it generates an acknowledgment signal. After that, it generates an acknowledgment signal by receiving the 8-bit word address. By these operations, the memory address is loaded into the address counter in the S-34C02A.

After this, in Byte Write and Page Write, the S-34C02A receives Write data, but in Dummy Write, the S-34C02A does not receive data.

Since the memory address has been loaded into the memory address counter by Dummy Write, the master device sends a start condition newly and performs the same operation as current Read. The users can read data which starts from the arbitrary memory address.

Thus, the S-34C02A receives the 7-bit device address and the Read / Write instruction cord "1" after receiving a start condition, it generates an acknowledgment signal.

And 8-bit data is output from the S-34C02A synchronizing with the SCL clock. After that, the Read operation ends when the master device transmits a stop condition, not an acknowledgment signal.

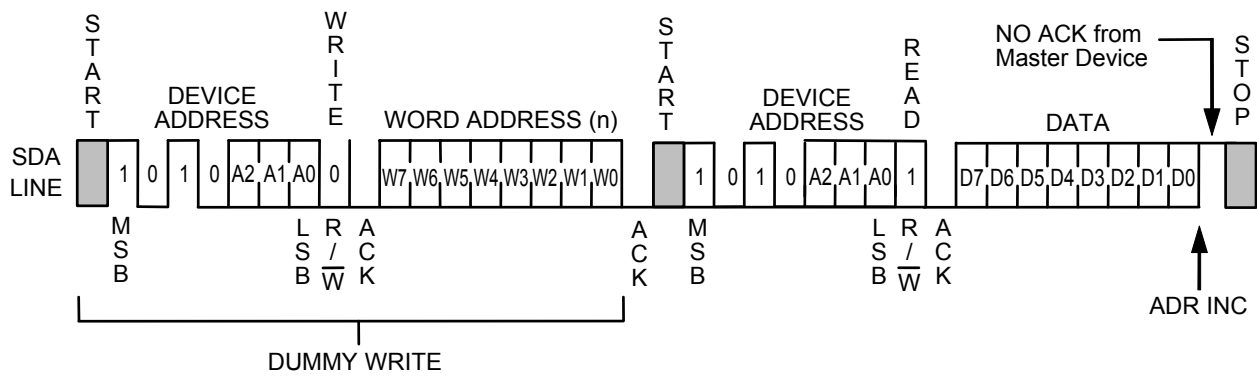

**Figure 15 Random Read**

**7.3 Sequential read**

Both in current Read and random Read, when the S-34C02A receives the 7-bit device address and Read / Write instruction code "1" after receiving a start condition, it generates an acknowledgment signal.

When 8-bit data is output from the S-34C02A synchronizing with the SCL clock, a memory address counter in the S-34C02A is automatically incremented at a falling edge of SCL clock right after the output of 8th bit data.

After that, the master device transmits an acknowledgment signal, the next data in the memory data address is output. A memory address counter in the S-34C02A is incremented because the master device transmits an acknowledge signal, so that the S-34C02A keeps reading data sequentially. This is sequential read.

The Read operation ends when the master device transmits a stop condition, not an acknowledgment signal.

Although the S-34C02A can read data sequentially in this sequential read, if a memory address counter reaches the last word address, it rolls over to the first memory address.

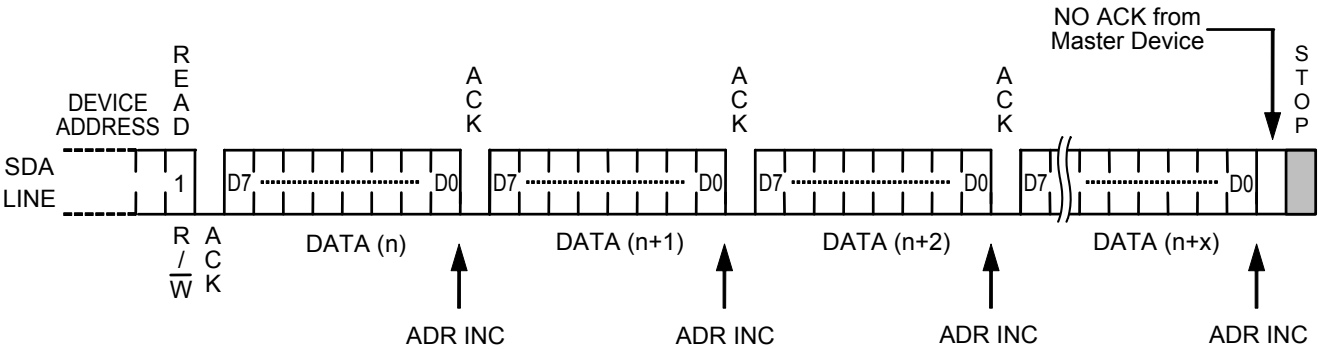

**Figure 16 Sequential Read**

8. Address increment timing

In the Read operation, the timing when a memory address counter is automatically incremented is at a falling edge of the SCL clock right after the output of 8th bit.  
In the Write operation, that timing is at a falling edge of the SCL clock when installing the 8th bit data.

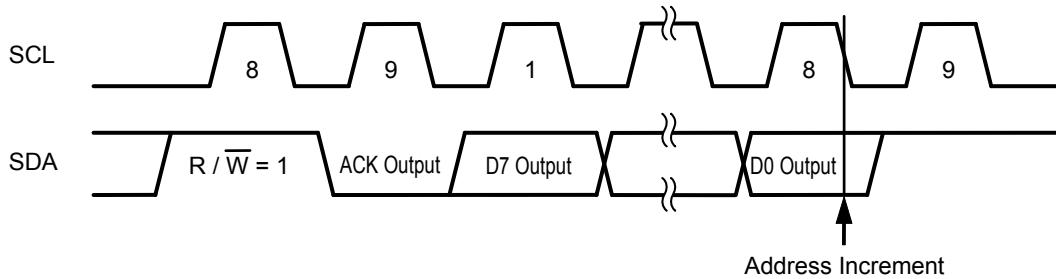

Figure 17 Address Increment Timing in Reading

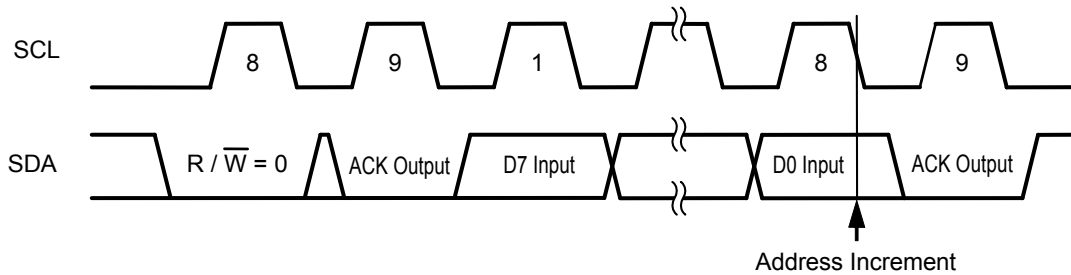

Figure 18 Address Increment Timing in Writing

■ Write Protect Function during the Low Power Supply Voltage

The S-34C02A has a built-in detection circuit which operates with the low power supply voltage, cancels Write when the power supply voltage drops and power-on. Its detection and release voltages are 1.20 V typ. (Refer to **Figure 19**). The S-34C02A cancels Write by detecting a low power supply voltage when it receives a stop condition. In the data transmission and the Write operation, data in the address written during the low power supply voltage is not assurable.

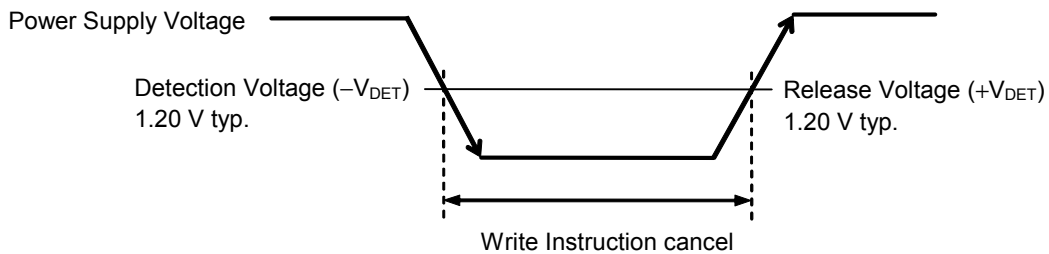

Figure 19 Operation during the Low Power Supply Voltage

■ **Using S-34C02A**

**1. Adding a pull-up resistor to SDA I/O pin and SCL input pin**

In consideration of I<sup>2</sup>C-bus protocol function, the SDA I/O and SCL input pins\*<sup>1</sup> should be connected with a pull-up resistor of 1 kΩ to 5 kΩ

The S-34C02A cannot transmit normally without using a pull-up resistor.

\*1. In case that the SCL input pin of the S-34C02A is connected to the tri-state output pin in the master device, connect the SCL pin with a pull-up resistor as well in order not to set the SCL input pin in high impedance. This prevents the S-34C02A from error caused by an uncertain output (high impedance) from the tri-state pin when resetting the master device during the voltage drop.

**2. Equivalent circuit of input and I/O pin**

Each input pin (A0, A1, A2, WP) of the S-34C02A has a built-in pull-down resistor. The SDA line has an open-drain output. The followings are equivalent circuits of the pins.

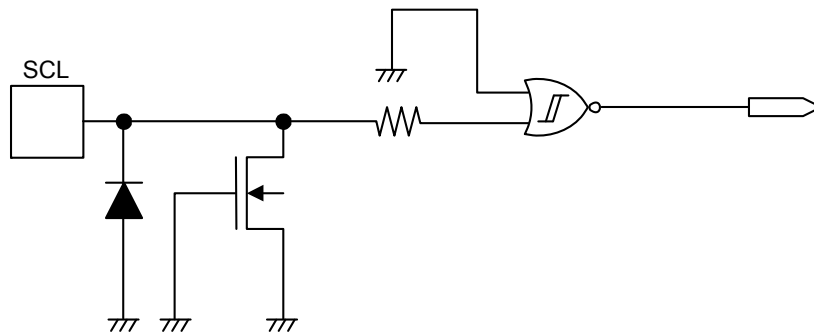

Figure 20 SCL Pin

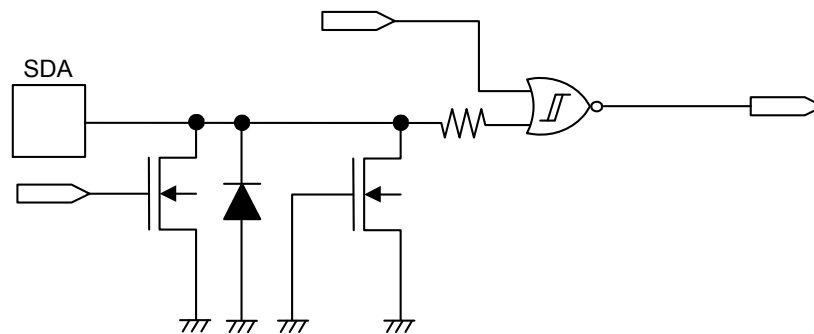

Figure 21 SDA Pin

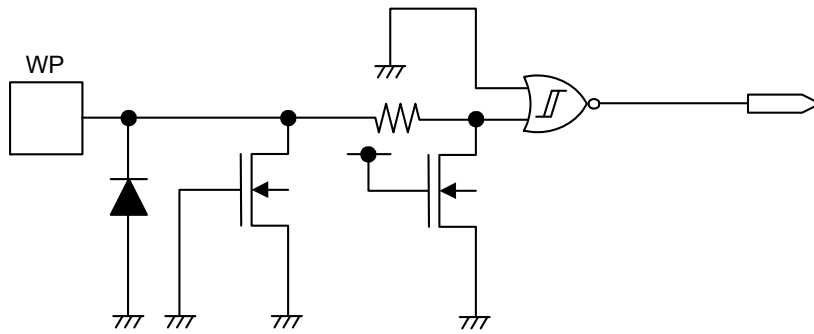

Figure 22 WP Pin

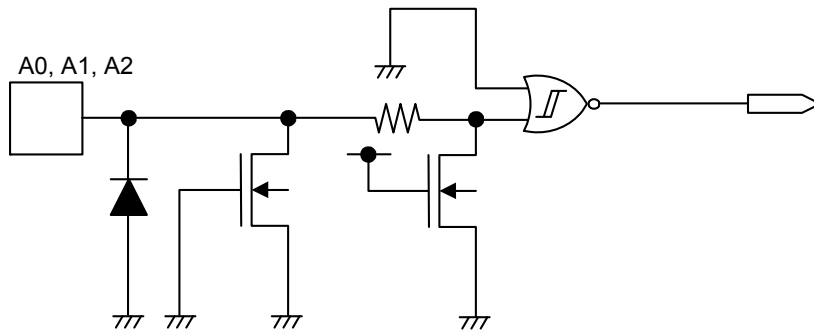

Figure 23 A0, A1, A2 Pin

**3. Phase adjustment during S-34C02A access**

The S-34C02A does not have a pin to reset (the internal circuit). The users cannot forcibly reset it externally. If the communication to the S-34C02A interrupted, the users need to handle it as you do for software.

Although the reset signal is input to the master device, the S-34C02A's internal circuit does not go in reset, but it does by inputting a stop condition to the S-34C02A. The S-34C02A keeps the same status thus cannot do the next operation. Especially, this case corresponds to that only the master device is reset when the power supply voltage drops.

If the power supply voltage restored in this status, input the instruction after resetting (adjusting the phase with the master device) the S-34C02A. How to reset is shown below.

**[How to reset S-34C02A]**

The S-34C02A is able to be reset by a start and stop instructions. When the S-34C02A is reading data "0" or is outputting the acknowledgment signal, outputs "0" to the SDA line. In this status, the master device cannot output an instruction to the SDA line. In this case, terminate the acknowledgment output operation or the Read operation, and then input a start instruction. **Figure 24** shows this procedure.

First, input a start condition. Then transmit 9 clocks (dummy clock) of SCL. During this time, the master device sets the SDA line to "H". By this operation, the S-34C02A interrupts the acknowledgment output operation or data output, so input a start condition<sup>\*1</sup>. When a start condition is input, the S-34C02A is reset. To make doubly sure, input the stop condition to the S-34C02A. The normal operation is then possible.

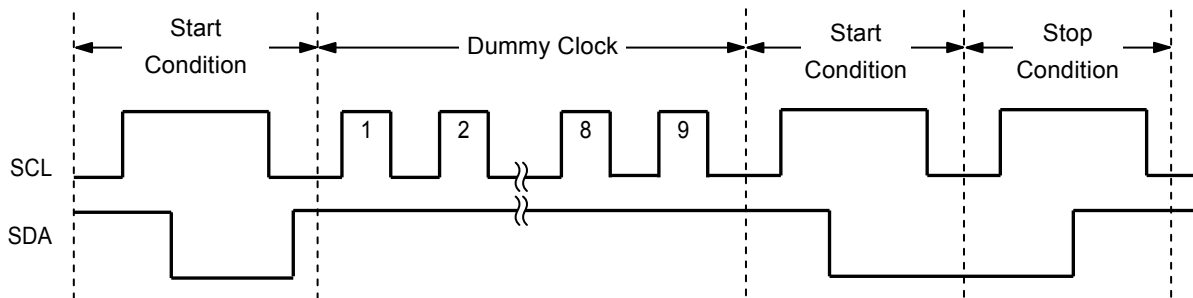

**Figure 24 Resetting S-34C02A**

<sup>\*1</sup>. After 9 clocks (dummy clock), if the SCL clock continues to being output without inputting a start condition, the S-34C02A may go in the Write operation when it receives a stop condition. To prevent this, input a start condition after 9 clock (dummy clock).

**Remark** Regarding this reset procedure with dummy clock, it is recommended to perform at the system initialization after applying the power supply voltage.

**4. Acknowledge check**

The I<sup>2</sup>C-bus protocol includes an acknowledge check function as a handshake function to prevent a communication error. This function allows detection of a communication failure during data communication between the master device and the S-34C02A. This function is effective to prevent malfunction, so it is recommended to perform an acknowledge check with the master device.

**5. Built-in power-on-clear circuit**

The S-34C02A has a built-in power-on-clear circuit that initializes itself at the same time during power-on. Unsuccessful initialization may cause a malfunction. To operate the power-on-clear circuit normally, the following conditions must be satisfied to raise the power supply voltage.

**5.1 Raising power supply voltage**

Shown in **Figure 25**, raise the power supply voltage from 0.2 V max., within the time defined as  $t_{RISE}$  which is the time required to reach the power supply voltage to be set.

For example, if the power supply voltage is 5.0 V,  $t_{RISE} = 200$  ms seen in **Figure 26**. The power supply voltage must be raised within 200 ms.

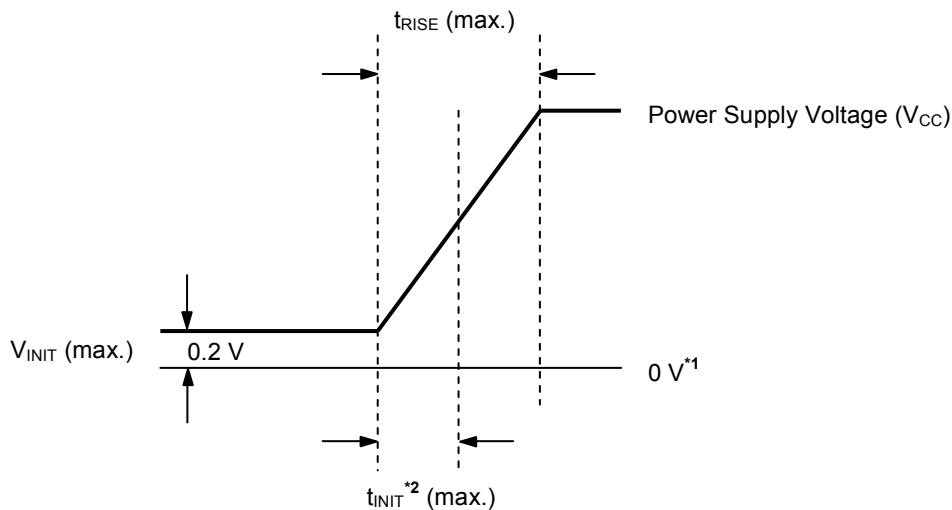

\*1. 0 V means there is no difference in potential between the  $V_{CC}$  pin and the GND pin of the S-34C02A.  
\*2.  $t_{INIT}$  is the time required to initialize the S-34C02A. No instructions are accepted during this time.

**Figure 25 Raising Power Supply Voltage**

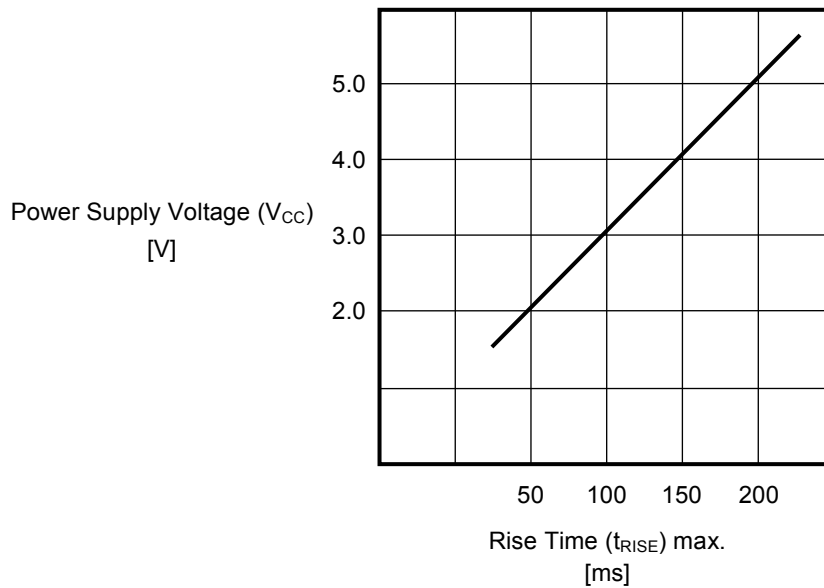

For example: If the supply voltage = 5.0 V, raise the power supply voltage to 5.0 V within 200 ms.

**Figure 26 Rise Time of Power Supply Voltage**

When initialization is successfully completed by the power-on-clear circuit, the S-34C02A enters the standby status.

If the power-on-clear circuit does not operate;

The S-34C02A has not completed initialization, an instruction previously input is still valid or an instruction may be inappropriately recognized. In this case, S-34C02A may perform the Write operation.

The voltage drops due to power off while the S-34C02A is being accessed. Even if the master device is reset due to the low power voltage, the S-34C02A may malfunction unless the power-on-clear operation conditions of S-34C02A are satisfied.

When not using this rise time seen in **Figure 26**, adjust the phase (reset) to reset the internal circuit in the S-34C02A normally.

**5.2 Initialization time**

The S-34C02A initializes at the same time when the power supply voltage is raised. Input instructions to the S-34C02A after initialization. The S-34C02A does not accept any instruction during initialization.

**Figure 27** shows the initialization time of the S-34C02A.

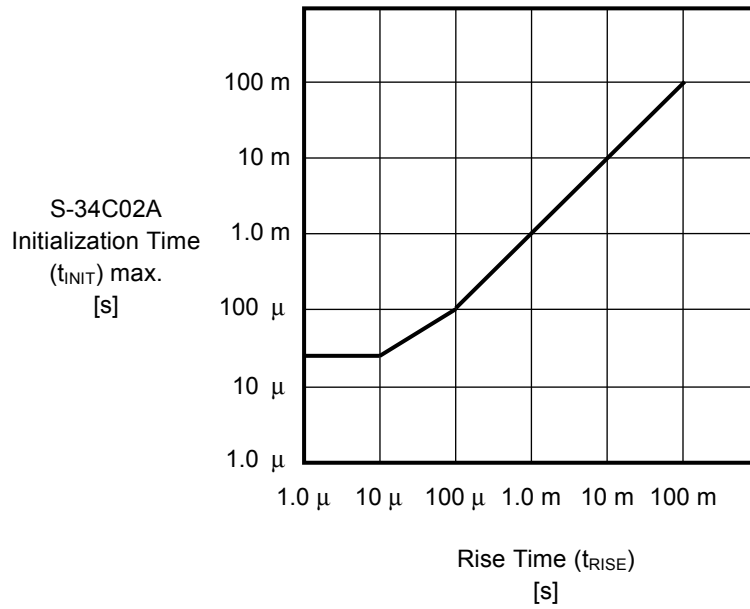
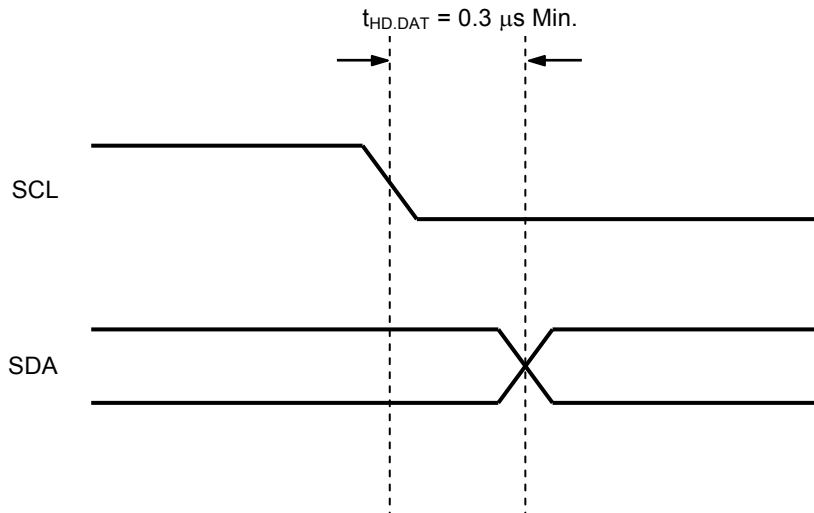

**Figure 27 Initialization Time of S-34C02A**

**6. Data hold time ( $t_{HD,DAT} = 0 \text{ ns}$ )**

If SCL and SDA of the S-34C02A are changed at the same time, it is necessary to prevent a start / stop condition from being mistakenly recognized due to the effect of noise. If a start / stop condition is mistakenly recognized during communication, the S-34C02A enters the standby status.

In the S-34C02A, it is recommended to set the delay time of  $0.3 \mu\text{s}$  minimum from a falling edge of SCL for the SDA. This is to prevent the S-34C02A from going in a start / stop condition due to the time lag caused by the load of the bus line.



**Figure 28 S-34C02A Data Hold Time**

**7. SDA pin and SCL pin noise suppression time**

The S-34C02A includes a built-in low-pass filter at the SDA and SCL pins to suppress noise. This means that if the power supply voltage is  $5.0 \text{ V}$ , noise with a pulse width of  $160 \text{ ns}$  or less can be suppressed. For details of the assurable value, refer to noise suppression time ( $t_i$ ) in **Table 11**.

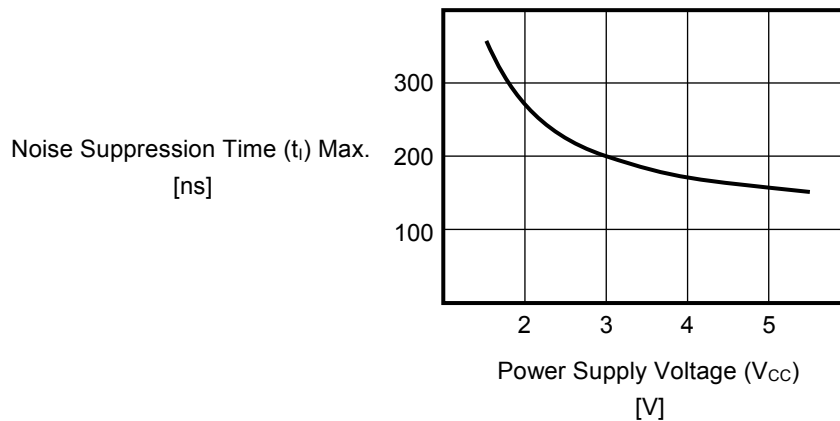

**Figure 29 Noise Suppression Time for SDA and SCL Pins**

**8. S-34C02A operation when inputting a stop condition with the clock less than the defined data length (less than 8-bit) to the SCL pin inputting Write data**

If the S-34C02A forcibly receives a stop condition while it is receiving Write data of 1 byte, it does not perform the Write operation.

To operate Page Write, if the S-34C02A receives a stop condition after receiving data of 1 byte or more, the S-34C02A operates Write only in the address equivalent to the byte of which the S-34C02A normally received 8-bit data before a stop condition.

**9. S-34C02A operation and data if inputting write data more than the defined page size during page write**

The S-34C02A is able to Page Write of 16 bytes, but in case if it receives data of 17 bytes, 8-bit data of the 17th byte is overwritten in the first byte in the same page because the S-34C02A cannot Write data across the page address.

**10. Precautions for use**

Absolute maximum ratings: Do not operate these ICs in excess of the absolute maximum ratings (as listed on the data sheet). Exceeding the supply voltage rating can cause latch-up.

Operations with moisture on the S-34C02A pins may occur malfunction by short-circuit between pins. Especially, in occasions like picking the S-34C02A up from low temperature tank during the evaluation. Be sure that not remain frost on the S-34C02A pin to prevent malfunction by short-circuit.

Also attention should be paid in using on environment, which is easy to dew for the same reason.

## ■ Precautions

- Do not apply an electrostatic discharge to this IC that exceeds the performance ratings of the built-in electrostatic protection circuit.
- SII claims no responsibility for any and all disputes arising out of or in connection with any infringement of the products including this IC upon patents owned by a third party.

■ Product Name Structures

1. Product name

1.1 8-Pin TSSOP

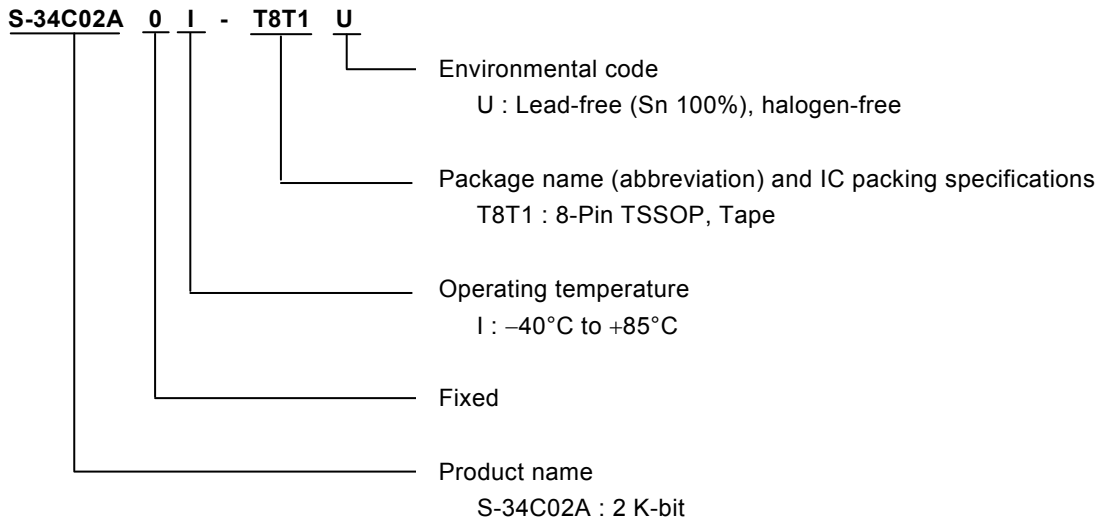

1.2 PLP-8C

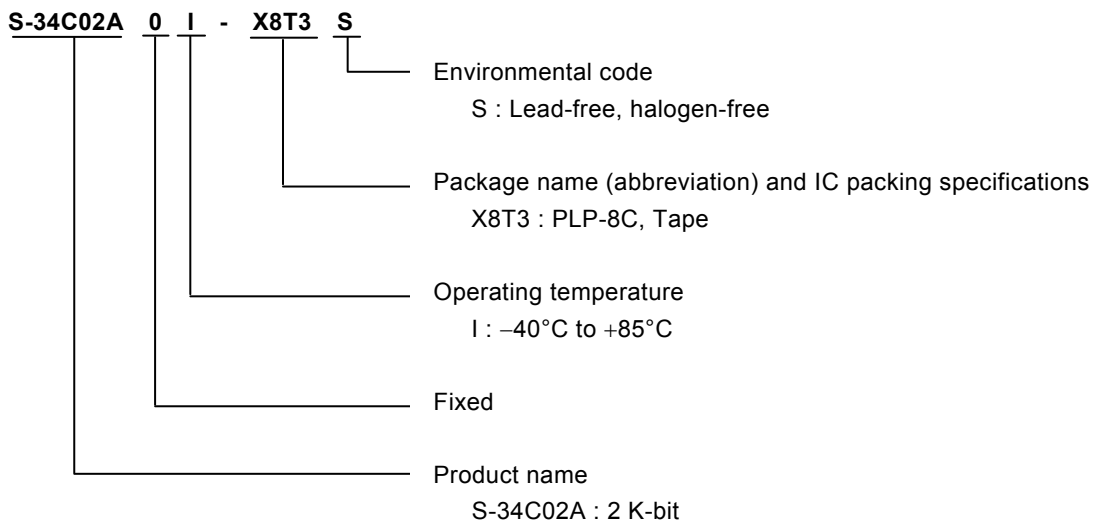

2. Packages

Package Name	Drawing Code		
	Package	Tape	Reel
8-Pin TSSOP	FT008-A-P-SD	FT008-E-C-SD	FT008-E-R-SD
PLP-8C	XC008-A-P-SD	XC008-A-C-SD	XC008-A-R-SD

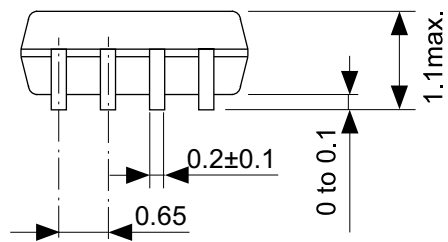
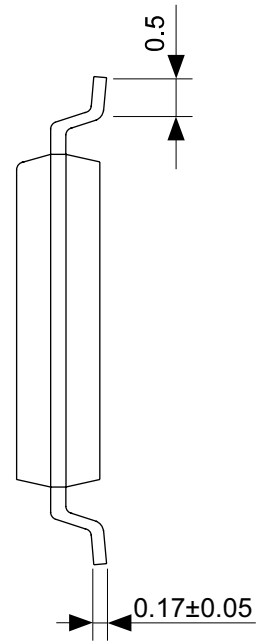
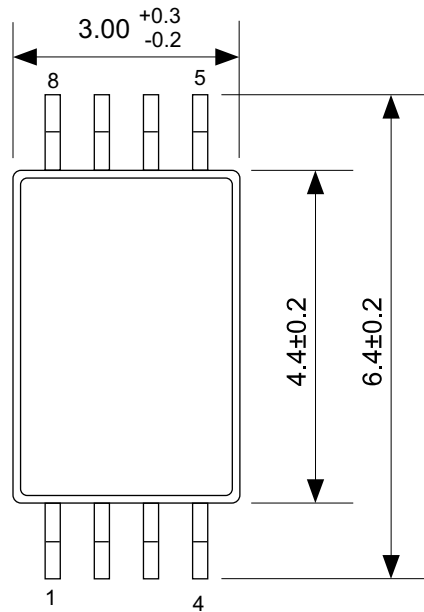

No. FT008-A-P-SD-1.1

TITLE	TSSOP8-E-PKG Dimensions
No.	FT008-A-P-SD-1.1
SCALE	
UNIT	mm
Seiko Instruments Inc.	

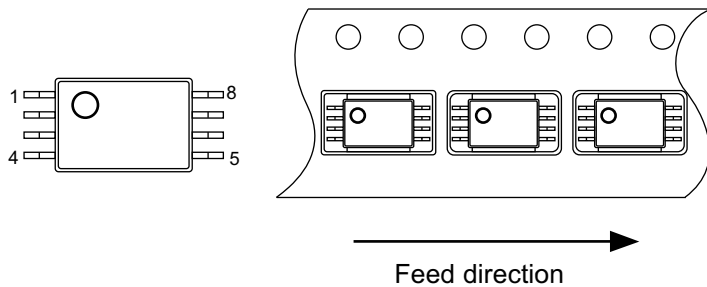
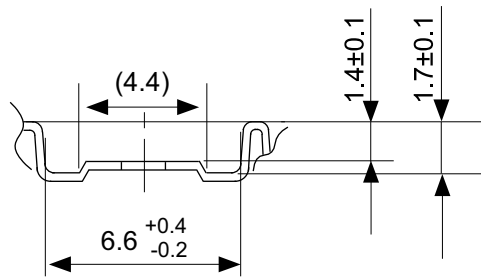
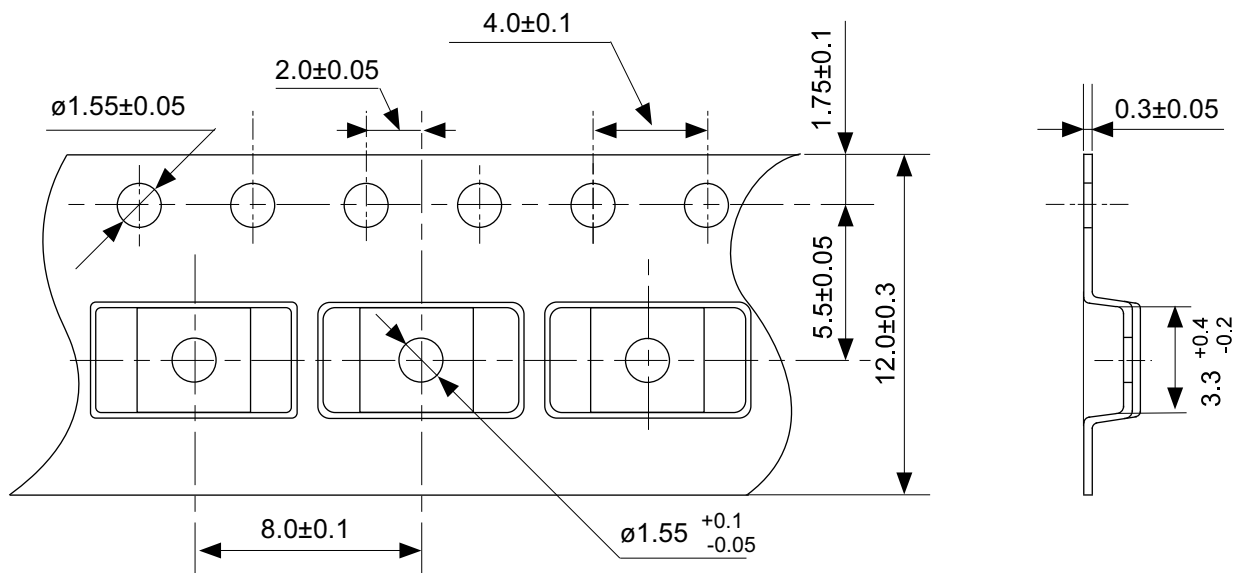

No. FT008-E-C-SD-1.0

TITLE	TSSOP8-E-Carrier Tape
No.	FT008-E-C-SD-1.0
SCALE	
UNIT	mm
Seiko Instruments Inc.	

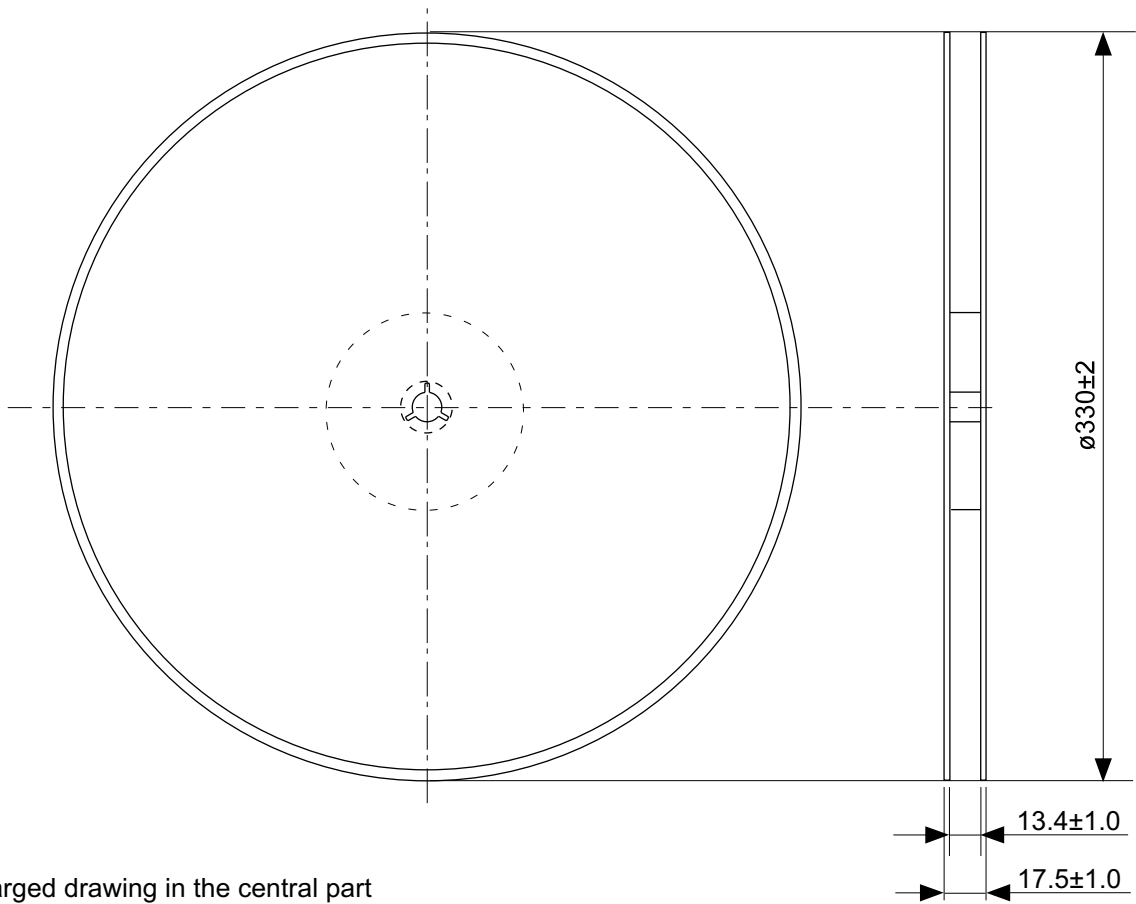

Enlarged drawing in the central part

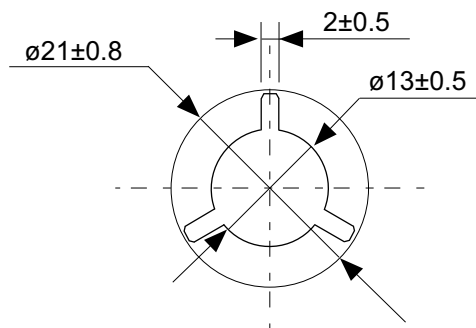

No. FT008-E-R-SD-1.0

TITLE	TSSOP8-E-Reel		
No.	FT008-E-R-SD-1.0		
SCALE		QTY.	3,000
UNIT	mm		
Seiko Instruments Inc.			

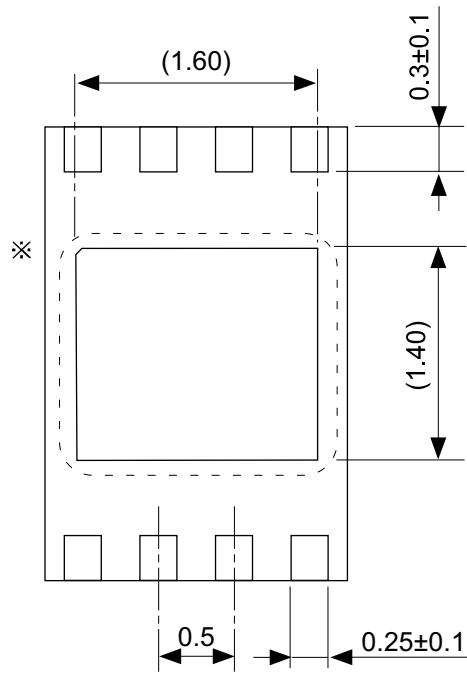
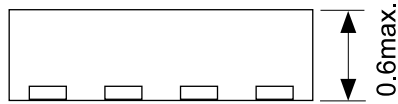
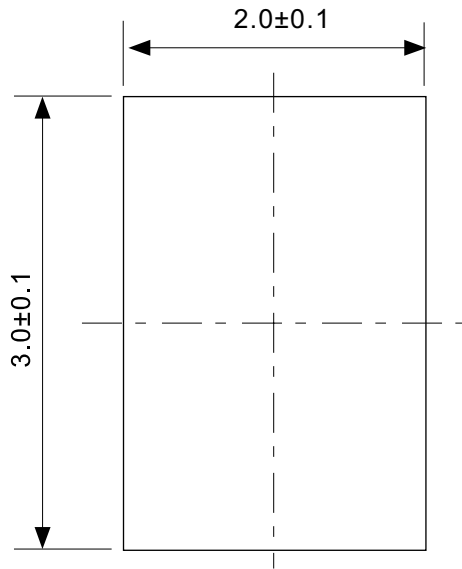

No. XC008-A-P-SD-1.0

※ The heatsink of back side has different electric potential depending on the product.  
 Confirm specifications of each product.  
 Do not use it as the function of electrode.

TITLE	PLP8C-A-PKG Dimensions
No.	XC008-A-P-SD-1.0
SCALE	
UNIT	mm
Seiko Instruments Inc.	

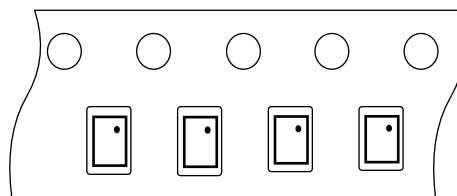
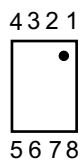
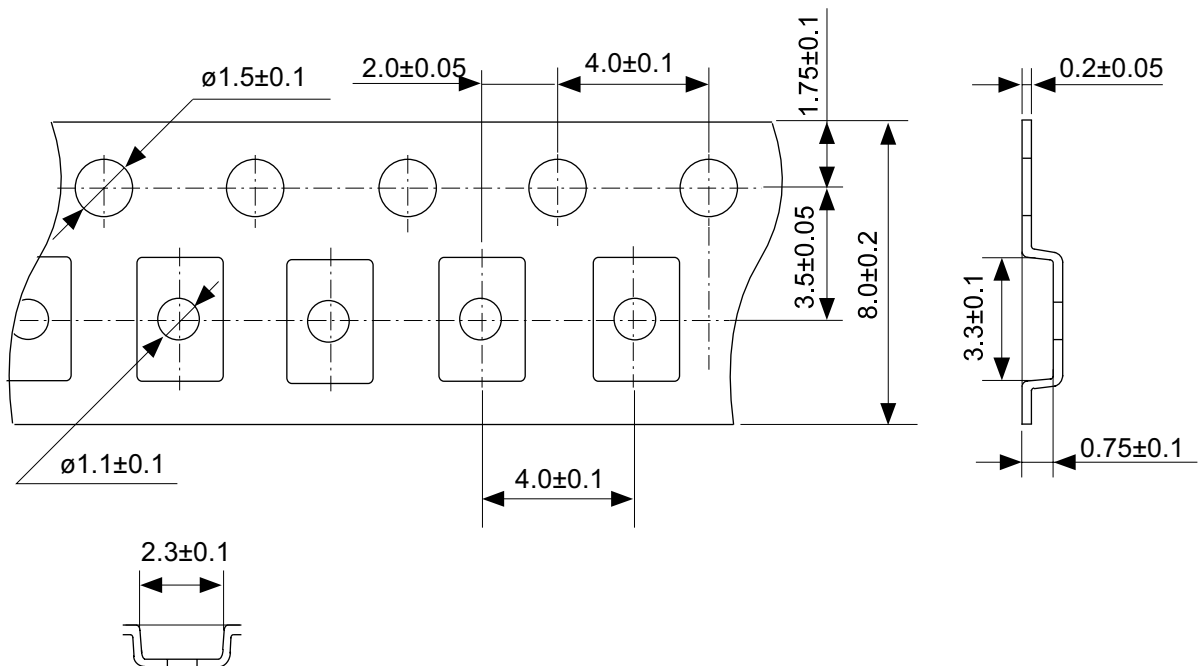

Feed direction →

No. XC008-A-C-SD-1.0

TITLE	PLP8C-A-Carrier Tape
No.	XC008-A-C-SD-1.0
SCALE	
UNIT	mm
Seiko Instruments Inc.	

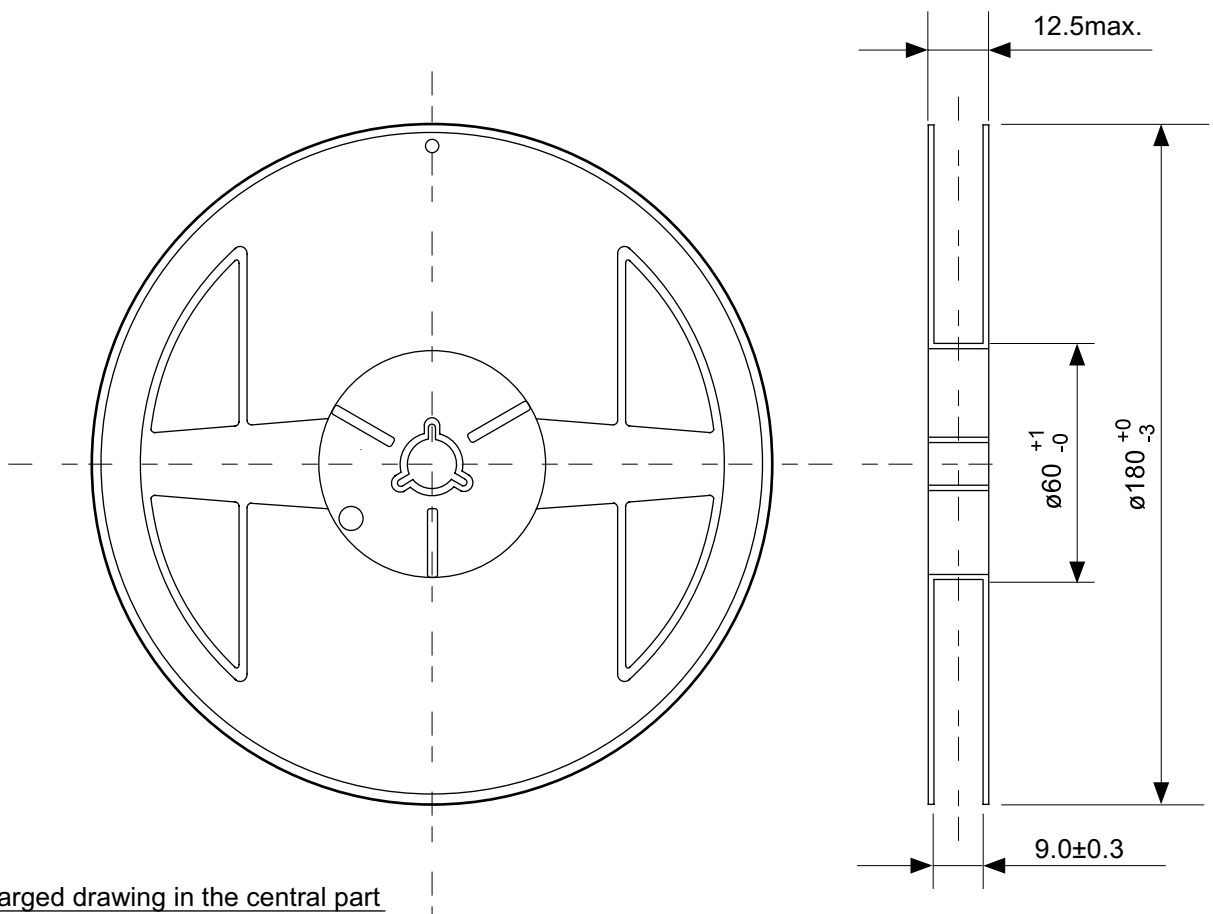

Enlarged drawing in the central part

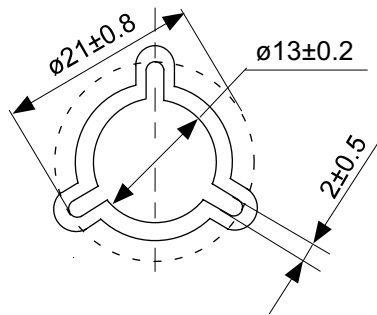

No. XC008-A-R-SD-1.0

TITLE	PLP8C-A-Reel		
No.	XC008-A-R-SD-1.0		
SCALE		QTY.	5,000
UNIT	mm		
Seiko Instruments Inc.			



Seiko Instruments Inc.  
[www.sii-ic.com](http://www.sii-ic.com)

- The information described herein is subject to change without notice.
- Seiko Instruments Inc. is not responsible for any problems caused by circuits or diagrams described herein whose related industrial properties, patents, or other rights belong to third parties. The application circuit examples explain typical applications of the products, and do not guarantee the success of any specific mass-production design.
- When the products described herein are regulated products subject to the Wassenaar Arrangement or other agreements, they may not be exported without authorization from the appropriate governmental authority.
- Use of the information described herein for other purposes and/or reproduction or copying without the express permission of Seiko Instruments Inc. is strictly prohibited.
- The products described herein cannot be used as part of any device or equipment affecting the human body, such as exercise equipment, medical equipment, security systems, gas equipment, or any apparatus installed in airplanes and other vehicles, without prior written permission of Seiko Instruments Inc.
- Although Seiko Instruments Inc. exerts the greatest possible effort to ensure high quality and reliability, the failure or malfunction of semiconductor products may occur. The user of these products should therefore give thorough consideration to safety design, including redundancy, fire-prevention measures, and malfunction prevention, to prevent any accidents, fires, or community damage that may ensue.