

TEMPERATURE SWITCH IC

www.sii-ic.com

© Seiko Instruments Inc., 2007-2010

Rev.2.0_00

The S-5841 Series is a temperature switch IC which detects the temperature with a temperature accuracy of $\pm 2.5^{\circ}\text{C}$. This IC restores the output voltage when the temperature drops to the level of release temperature.

The S-5841 operates at the lower power supply voltage of 2.2 V and its current consumption is 10 μA Typ. due to CMOS configuration.

A temperature sensor with the negative temperature coefficient, a reference voltage generation circuit and a comparator are integrated on one chip, and enclosed into the small packages SNT-6A and SOT-23-5.

■ Features

- Detection temperature : $+40^{\circ}\text{C}$ to $+100^{\circ}\text{C}$, $+1^{\circ}\text{C}$ steps, detection accuracy : $\pm 2.5^{\circ}\text{C}$
- Low voltage operation : $V_{\text{DD}} (\text{min.}) = 2.2 \text{ V}$
(When the detection temperature is $+55^{\circ}\text{C}$ to $+100^{\circ}\text{C}$, $T_{\text{a}} = -40^{\circ}\text{C}$ to $+100^{\circ}\text{C}$)
- Low current consumption : 10 μA typ. ($T_{\text{a}} = +25^{\circ}\text{C}$)
- Hysteresis temperature can be switched in 0°C , 2°C , 4°C and 10°C
- Selectable output logic in active high or low
- Selectable output form in CMOS or Nch open drain
- Lead-free, Sn 100%, halogen-free^{*1}

*1. Refer to “■ Product Name Structure” for details.

■ Applications

- Fan control
- Air conditioning system
- Various electronic device

■ Packages

- SNT-6A
- SOT-23-5

■ Block Diagrams

1. CMOS output product

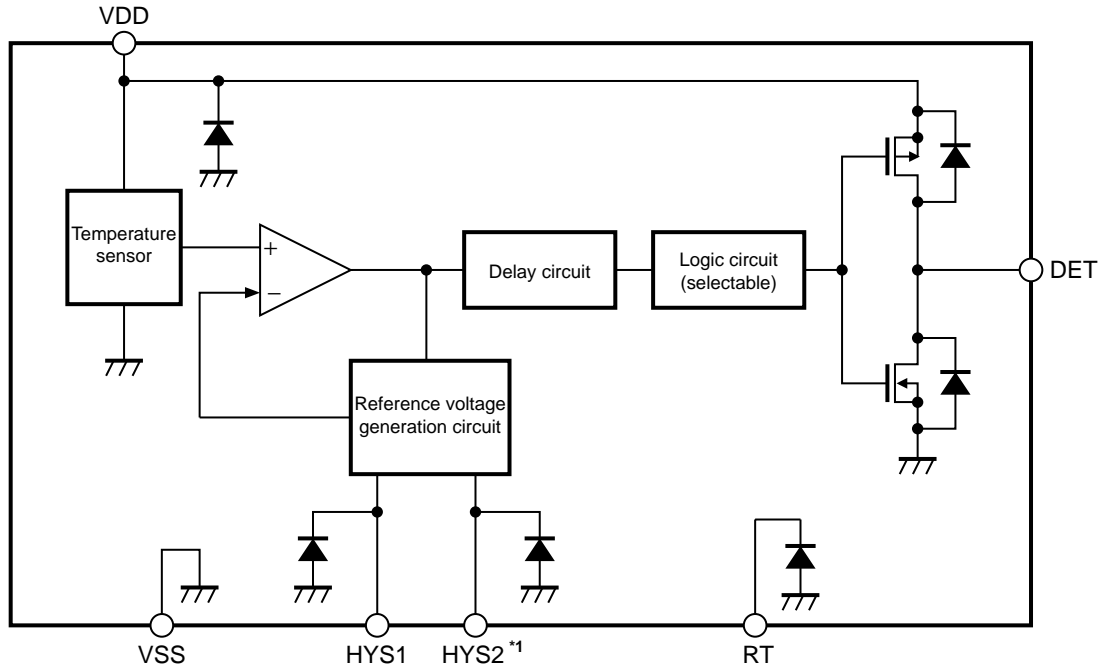

*1. The HYS2 pin is not equipped for the S-5841 with SOT-23-5.

Figure 1

2. Nch open drain output product

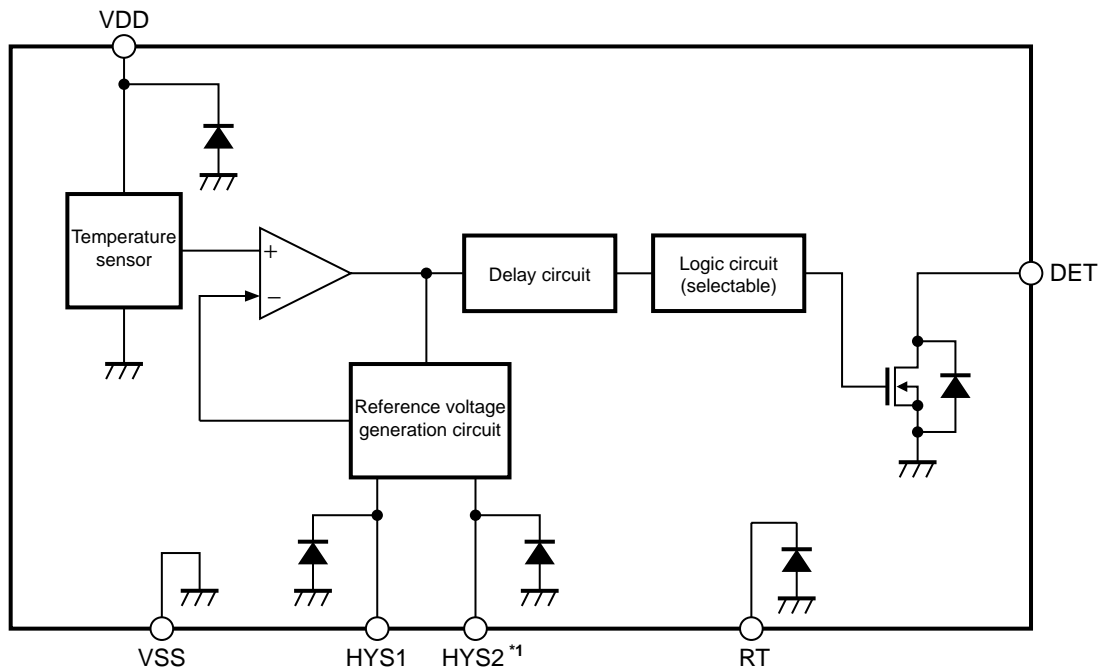

*1. The HYS2 pin is not equipped for the S-5841 with SOT-23-5.

Figure 2

■ Product Name Structure

1. Product name

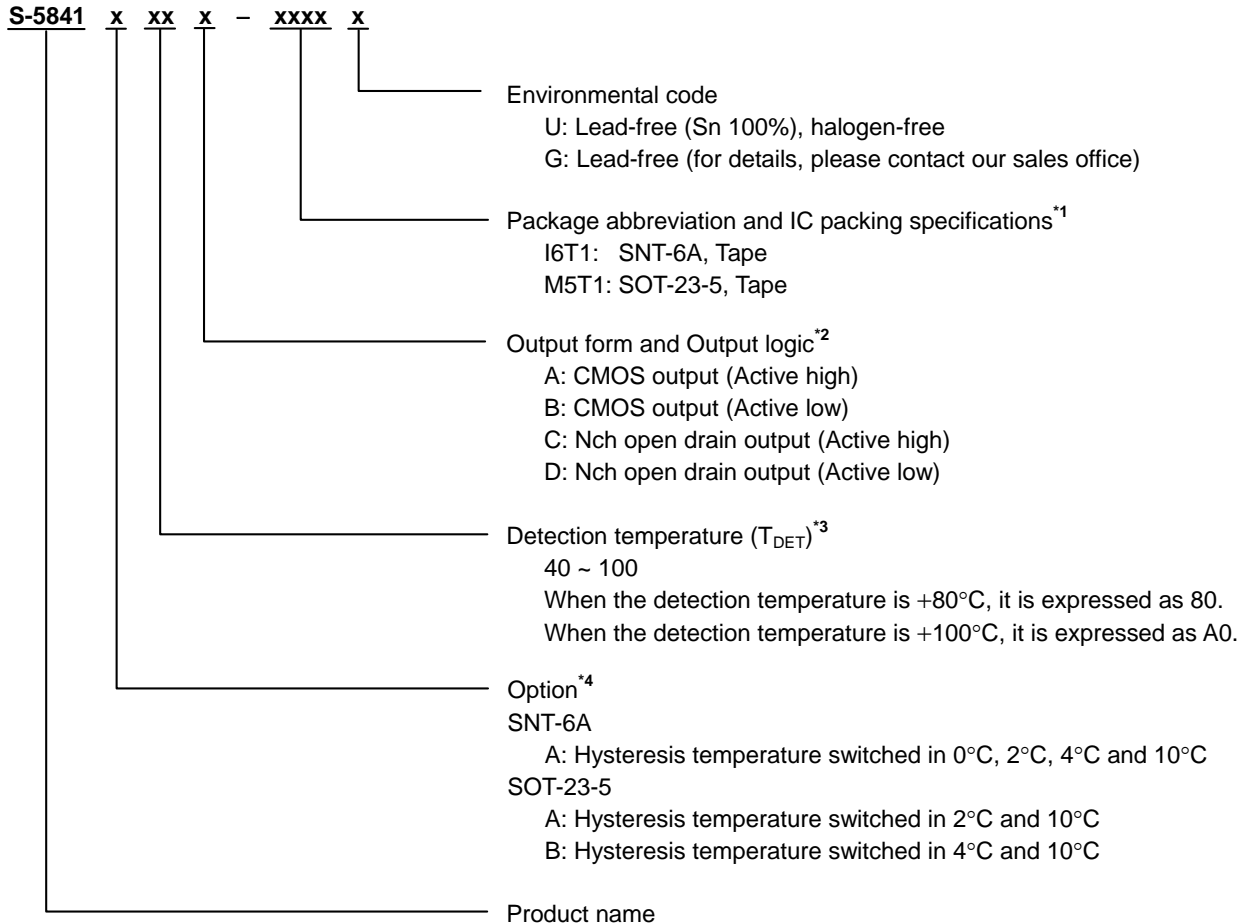

*1. Refer to the tape specifications.

*2. The output at the DET pin is selectable in either active high or low.
The output at the DET pin is selectable in either CMOS or Nch open drain.

*3. The detection temperature (T_{DET}) can be set in the range of +40°C to +100°C at +1°C step.
(We offer a detection temperature setting for each customer individually. Contact our sales office for details.)

*4. The hysteresis temperature can be switched in 0°C, 2°C, 4°C, 10°C, and is set by the HYS1 pin and HYS2 pin in the S-5841 with SNT-6A package.
The hysteresis temperature is set by HYS1 pin in the S-5841 with SOT-23-5 package. By option, the hysteresis temperature of the product is selectable in 2°C and 10°C / 4°C and 10°C.

2. Package

Package name	Drawing Code			
	Package	Tape	Reel	Land
SNT-6A	PG006-A-P-SD	PG006-A-C-SD	PG006-A-R-SD	PG006-A-L-SD
SOT-23-5	MP005-A-P-SD	MP005-A-C-SD	MP005-A-R-SD	—

3. Product List

(1) SNT-6A

Table 1

Product name / Item	Detection temperature (T _{DET})	DET Pin output logic	DET Pin output form	Hysteresis temperature
S-5841A70A-I6T1x	+70°C	Active high	CMOS	0°C, 2°C, 4°C, 10°C
S-5841A80A-I6T1x	+80°C	Active high	CMOS	0°C, 2°C, 4°C, 10°C
S-5841A90A-I6T1x	+90°C	Active high	CMOS	0°C, 2°C, 4°C, 10°C
S-5841A50D-I6T1x	+50°C	Active low	Nch open drain	0°C, 2°C, 4°C, 10°C

Remark1. Please contact our sales office for products other than those specified above.

2. x: G or U

3. Please select products of environmental code = U for Sn 100%, halogen-free products.

(2) SOT-23-5

Table 2

Product name / Item	Detection temperature (T _{DET})	DET Pin output logic	DET Pin output form	Hysteresis temperature
S-5841A55D-M5T1x	+55°C	Active low	Nch open drain	2°C, 10°C
S-5841A65D-M5T1x	+65°C	Active low	Nch open drain	2°C, 10°C
S-5841A75D-M5T1x	+75°C	Active low	Nch open drain	2°C, 10°C
S-5841A85D-M5T1x	+85°C	Active low	Nch open drain	2°C, 10°C
S-5841A95D-M5T1x	+95°C	Active low	Nch open drain	2°C, 10°C

Remark1. Please contact our sales office for products other than those specified above.

2. x: G or U

3. Please select products of environmental code = U for Sn 100%, halogen-free products.

■ Pin Configurations

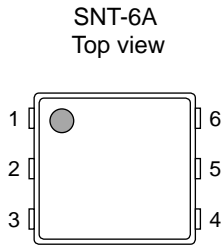

Figure 3

Table 3

Pin No.	Symbol	Description
1	RT ^{*1}	Test pin
2	VSS	GND pin
3	HYS1 ^{*2}	Hysteresis pin 1
4	DET	Output pin
5	HYS2 ^{*2}	Hysteresis pin 2
6	VDD	Power supply pin

- *1. Set the RT pin open in use.
- *2. Fix the HYS1 pin and the HYS2 pin as VDD or VSS in use.

Remark See Dimensions for details of the package drawings.

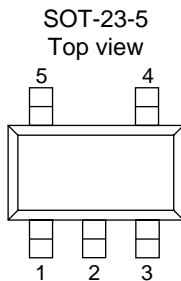

Figure 4

Table 4

Pin No.	Symbol	Description
1	HYS1 ^{*1}	Hysteresis pin 1
2	VSS	GND pin
3	RT ^{*2}	Test pin
4	VDD	Power supply pin
5	DET	Output pin

- *1. The HYS2 pin is not equipped for the S-5841 with SOT-23-5.
Fix HYS1 pin as VDD or VSS.
- *2. Set the RT pin open in use.

Remark See Dimensions for details of the package drawings.

■ Absolute Maximum Ratings

Table 5

(Ta = +25°C unless otherwise specified)

Item		Symbol	Absolute Maximum Ratings	Unit
Power supply voltage (V _{SS} = 0 V)		V _{DD}	V _{SS} +12	V
Pin voltage		V _{RT} , V _{HYS1} , V _{HYS2}	V _{SS} -0.3 to V _{DD} +0.3	V
Output voltage	CMOS output	V _{DET}	V _{SS} -0.3 to V _{DD} +0.3	V
	Nch open drain		V _{SS} -0.3 to V _{SS} +12	V
Power dissipation	SNT-6A	P _D	400 ^{*1}	mW
	SOT-23-5		600 ^{*1}	mW
Operating ambient temperature		T _{opr}	-40 to +125	°C
Storage temperature		T _{stg}	-55 to +150	°C

*1. When mounted on board

[Mounted board]

- (1) Board size : 114.3 mm × 76.2 mm × t1.6 mm
- (2) Board name : JEDEC STANDARD51-7

Caution The absolute maximum ratings are rated values exceeding which the product could suffer physical damage. These values must therefore not be exceeded under any conditions.

■ DC Electrical Characteristics

1. CMOS output product

(1) SNT-6A package

Table 6

(Ta = +25°C, unless otherwise specified)

Item	Symbol	Condition	Min.	Typ.	Max.	Unit	Test circuit
Power supply voltage*1	V _{DD}	+T _D = +55°C to +100°C	2.2	–	10.0	V	1
		+T _D = +40°C to +54°C	2.6	–	10.0	V	1
Detection temperature	+T _D	–	T _{DET} -2.5	T _{DET}	T _{DET} +2.5	°C	1
Hysteresis of detection temperature*2	T _{HYS}	HYS1	HYS2	–	–	–	–
		“H”	“H”	–	2	–	°C
		“H”	“L”	–	4	–	°C
		“L”	“H”	–	10	–	°C
		“L”	“L”	–	0	–	°C
Output current	I _{DETH}	V _{DD} = 3.0 V, apply for DET pin	V _{DET} = 2.2 V	2	9.4	–	mA
	I _{DETL}		V _{DET} = 0.4 V	0.5	2.3	–	mA
Current consumption during operation	I _{DD}	V _{DD} = 3.0 V	–	10	20	μA	1
HYS1 pin input voltage “H”	V _{IH}	–	0.8 × V _{DD}	–	–	V	3
HYS1 pin input voltage “L”	V _{IL}	–	–	–	0.2 × V _{DD}	V	3
HYS1 pin input current “H”	I _{IH}	V _{DD} = 3.0 V, V _{HYS1} = 3.0 V	–0.1	–	0.1	μA	3
HYS1 pin input current “L”	I _{IL}	V _{DD} = 3.0 V, V _{HYS1} = 0 V	–0.1	–	0.1	μA	3
HYS2 pin input voltage “H”	V _{IH}	–	0.8 × V _{DD}	–	–	V	3
HYS2 pin input voltage “L”	V _{IL}	–	–	–	0.2 × V _{DD}	V	3
HYS2 pin input current “H”	I _{IH}	V _{DD} = 3.0 V, V _{HYS2} = 3.0 V	–0.1	–	0.1	μA	3
HYS2 pin input current “L”	I _{IL}	V _{DD} = 3.0 V, V _{HYS2} = 0 V	–0.1	–	0.1	μA	3

*1. The minimum operation voltages are as follows under the operation ambient temperature over +100°C.

The detection temperature +55°C to +100°C, V_{DD} (min.) = 2.3 V

The detection temperature +40°C to +54°C, V_{DD} (min.) = 2.7 V

*2. The hysteresis temperature can be switched in 0°C, 2°C, 4°C, 10°C, and is set by the HYS1 pin and HYS2 pin in the S-5841 with SNT-6A package.

[Fahrenheit ⇔ Celsius Conversion equation]

$$^{\circ}\text{C} = (^{\circ}\text{F} - 32) \times 5 / 9$$

$$^{\circ}\text{F} = 32 + ^{\circ}\text{C} \times 9 / 5$$

(2) SOT-23-5 Package

Table 7

(Ta = +25°C, unless otherwise specified)

Item	Symbol	Condition		Min.	Typ.	Max.	Unit	Test circuit
Power supply voltage*1	V _{DD}	+T _D = +55°C to +100°C		2.2	–	10.0	V	1
		+T _D = +40°C to +54°C		2.6	–	10.0	V	1
Detection temperature	+T _D	–		T _{DET} -2.5	T _{DET}	T _{DET} +2.5	°C	1
Hysteresis of detection temperature*2	T _{HYS}	Hysteresis option	HYS1	–	–	–	–	–
		A	“H”	–	2	–	°C	1
			“L”	–	10	–	°C	1
		B	“H”	–	4	–	°C	1
“L”	–		10	–	°C	1		
Output current	I _{DETH}	V _{DD} = 3.0 V, apply for DET pin	V _{DET} = 2.2 V	2	9.4	–	mA	2
	I _{DETL}		V _{DET} = 0.4 V	0.5	2.3	–	mA	2
Current consumption during operation	I _{DD}	V _{DD} = 3.0 V		–	10	20	μA	1
HYS1 pin input voltage “H”	V _{IH}	–		0.8 × V _{DD}	–	–	V	3
HYS1 pin input voltage “L”	V _{IL}	–		–	–	0.2 × V _{DD}	V	3
HYS1 pin input current “H”	I _{IH}	V _{DD} = 3.0 V, V _{HYS1} = 3.0 V		–0.1	–	0.1	μA	3
HYS1 pin input current “L”	I _{IL}	V _{DD} = 3.0 V, V _{HYS1} = 0 V		–0.1	–	0.1	μA	3

*1. The minimum operation voltages are as follows under the operation ambient temperature over +100°C.
 The detection temperature +55°C to +100°C, V_{DD} (min.) = 2.3 V
 The detection temperature +40°C to +54°C, V_{DD} (min.) = 2.7 V

*2. In the S-5841 with SOT-23-5 package, the hysteresis temperature can be set by the HYS1 pin.
 These two types are selectable by option.
 Hysteresis option A : 2°C of hysteresis temperature during HYS1 = high level,
 10°C of hysteresis temperature during HYS1 = low level
 Hysteresis option B : 4°C of hysteresis temperature during HYS1 = high level,
 10°C of hysteresis temperature during HYS1 = low level

[Fahrenheit ↔ Celsius Conversion equation]

$$^{\circ}\text{C} = (^{\circ}\text{F} - 32) \times 5 / 9$$

$$^{\circ}\text{F} = 32 + ^{\circ}\text{C} \times 9 / 5$$

2. Nch open drain output

(1) SNT-6A package

Table 8

(Ta = +25°C, unless otherwise specified)

Item	Symbol	Condition	Min.	Typ.	Max.	Unit	Test circuit
Power supply voltage*1	V _{DD}	+T _D = +55°C to +100°C	2.2	–	10.0	V	1
		+T _D = +40°C to +54°C	2.6	–	10.0	V	1
Detection temperature	+T _D	–	T _{DET} -2.5	T _{DET}	T _{DET} +2.5	°C	1
Hysteresis of detection temperature*2	T _{HYS}	HYS1	–	–	–	–	–
		“H”	–	2	–	°C	1
		“H”	–	4	–	°C	1
		“L”	–	10	–	°C	1
		“L”	–	0	–	°C	1
Output current	I _{DETL}	V _{DET} = 0.4 V, V _{DD} = 3.0 V	0.5	2.3	–	mA	2
Leakage current	I _{LEAK}	V _{DET} = 10.0 V, V _{DD} = 3.0 V	–	–	100	nA	2
Current consumption during operation	I _{DD}	V _{DD} = 3.0 V	–	10	20	μA	1
HYS1 pin input voltage “H”	V _{IH}	–	0.8 × V _{DD}	–	–	V	3
HYS1 pin input voltage “L”	V _{IL}	–	–	–	0.2 × V _{DD}	V	3
HYS1 pin input current “H”	I _{IH}	V _{DD} = 3.0 V, V _{HYS1} = 3.0 V	–0.1	–	0.1	μA	3
HYS1 pin input current “L”	I _{IL}	V _{DD} = 3.0 V, V _{HYS1} = 0 V	–0.1	–	0.1	μA	3
HYS2 pin input voltage “H”	V _{IH}	–	0.8 × V _{DD}	–	–	V	3
HYS2 pin input voltage “L”	V _{IL}	–	–	–	0.2 × V _{DD}	V	3
HYS2 pin input current “H”	I _{IH}	V _{DD} = 3.0 V, V _{HYS2} = 3.0 V	–0.1	–	0.1	μA	3
HYS2 pin input current “L”	I _{IL}	V _{DD} = 3.0 V, V _{HYS2} = 0 V	–0.1	–	0.1	μA	3

*1. The minimum operation voltages are as follows under the operation ambient temperature over +100°C.
 The detection temperature +55°C to +100°C, V_{DD} (min.) = 2.3 V
 The detection temperature +40°C to +54°C, V_{DD} (min.) = 2.7 V

*2. The hysteresis temperature can be switched in 0°C, 2°C, 4°C, 10°C, and is set by the HYS1 pin and HYS2 pin in the S-5841 with SNT-6A package.

[Fahrenheit ↔ Celsius Conversion equation]

$$^{\circ}\text{C} = (^{\circ}\text{F} - 32) \times 5 / 9$$

$$^{\circ}\text{F} = 32 + ^{\circ}\text{C} \times 9 / 5$$

(2) SOT-23-5 package

Table 9

(Ta = +25°C, unless otherwise specified)

Item	Symbol	Condition	Min.	Typ.	Max.	Unit	Test circuit
Power supply voltage*1	V _{DD}	+T _D = +55°C to +100°C	2.2	–	10.0	V	1
		+T _D = +40°C to +54°C	2.6	–	10.0	V	1
Detection temperature	+T _D	–	T _{DET} -2.5	T _{DET}	T _{DET} +2.5	°C	1
Hysteresis of detection temperature*2	T _{HYS}	Hysteresis option	HYS1	–	–	–	–
		A	“H”	–	2	–	°C
			“L”	–	10	–	°C
		B	“H”	–	4	–	°C
“L”	–		10	–	°C		
Output current	I _{DETL}	V _{DET} = 0.4 V, V _{DD} = 3.0 V	0.5	2.3	–	mA	2
Leakage current	I _{LEAK}	V _{DET} = 10.0 V, V _{DD} = 3.0 V	–	–	100	nA	2
Current consumption during operation	I _{DD}	V _{DD} = 3.0 V	–	10	20	μA	1
HYS1 pin input voltage “H”	V _{IH}	–	0.8 × V _{DD}	–	–	V	3
HYS1 pin input voltage “L”	V _{IL}	–	–	–	0.2 × V _{DD}	V	3
HYS1 pin input current “H”	I _{IH}	V _{DD} = 3.0 V, V _{HYS1} = 3.0 V	–0.1	–	0.1	μA	3
HYS1 pin input current “L”	I _{IL}	V _{DD} = 3.0 V, V _{HYS1} = 0 V	–0.1	–	0.1	μA	3

*1. The minimum operation voltages are as follows under the operation ambient temperature over +100°C.
The detection temperature +55°C to +100°C, V_{DD} (min.) = 2.3 V
The detection temperature +40°C to +54°C, V_{DD} (min.) = 2.7 V

*2. In the S-5841 with SOT-23-5 package, the hysteresis temperature can be set by the HYS1 pin.
These two types are selectable by option.
Hysteresis option A : 2°C of hysteresis temperature during HYS1 = high level,
10°C of hysteresis temperature during HYS1 = low level
Hysteresis option B : 4°C of hysteresis temperature during HYS1 = high level,
10°C of hysteresis temperature during HYS1 = low level

[Fahrenheit ↔ Celsius Conversion equation]

$$^{\circ}\text{C} = (^{\circ}\text{F} - 32) \times 5 / 9$$

$$^{\circ}\text{F} = 32 + ^{\circ}\text{C} \times 9 / 5$$

■ AC Electrical Characteristics

Table 10

Item	Symbol	Condition	Min.	Typ.	Max.	Unit	Test circuit
Noise suppression time	t _{delay}	V _{DD} = 3.0 V, Ta = detection temperature	–	380	–	μs	–

■ Test circuit

1.

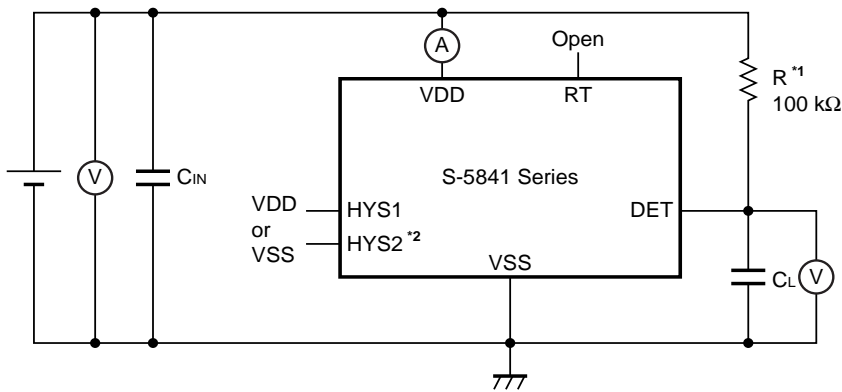

- *1. Resistor is unnecessary for the CMOS output product.
- *2. The HYS2 pin is not equipped for the S-5841 with SOT-23-5.

Figure 5

2.

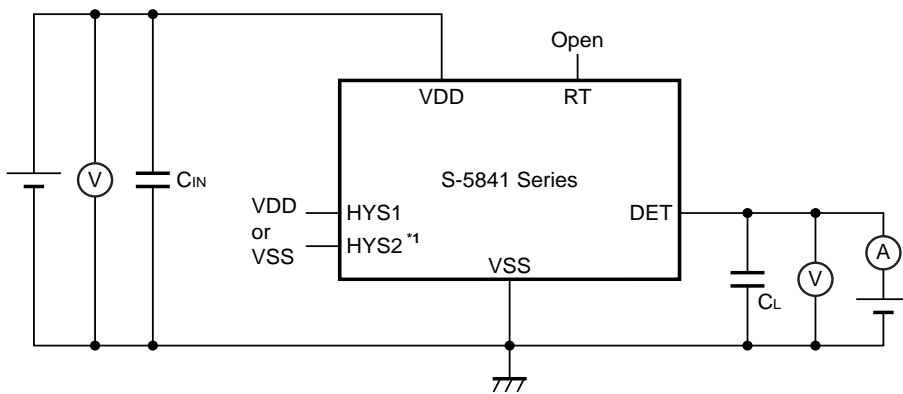

- *1. The HYS2 pin is not equipped for the S-5841 with SOT-23-5.

Figure 6

3.

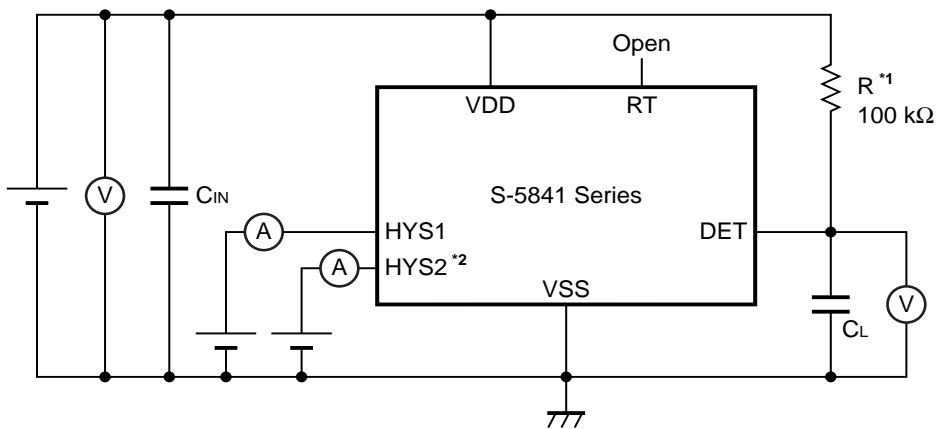

- *1. Resistor is unnecessary for the CMOS output product.
- *2. The HYS2 pin is not equipped for the S-5841 with SOT-23-5.

Figure 7

■ **Operation**

Basic operation

The S-5841 series is a temperature switch IC which detects a certain temperature and sends a signal to an external device. Various combinations of the parameters such as the detection temperature, output form and output logic can be selected.

The following explains the case when DET output is assumed to be active high and CMOS output. After applying the power supply, the IC starts to detect the temperature. If it is lower than the detection temperature ($+T_D$), the DET pin keeps its status in low level. The temperature rises and exceeds the detection temperature, the DET pin becomes high level. After the detection, the temperature drops and reaches the release temperature ($+T_D - T_{HYS}$), the DET pin returns to low level.

Figure 8 is the timing chart.

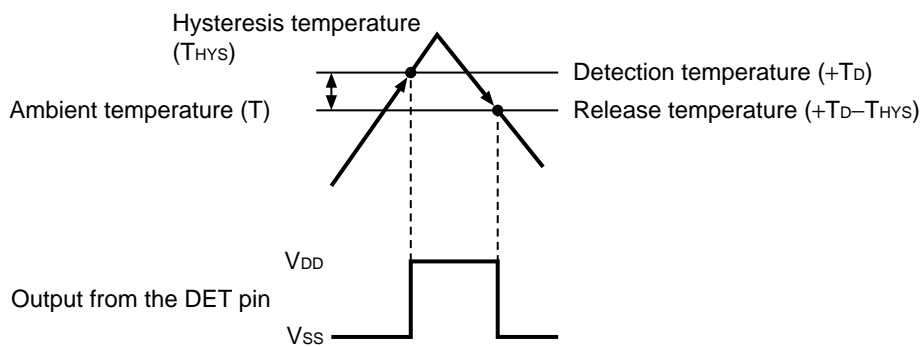

Figure 8 Operation when the output from DET pin is active high

[Hysteresis setting]

In the S-5841 with SNT-6A package, The hysteresis temperature can be switched in 0°C, 2°C, 4°C, 10°C, and is set by the HYS1 pin and HYS2 pin. In the S-5841 with SOT-23-5 package, the hysteresis temperature can be set by the HYS1 pin. By option, the hysteresis temperature of the product is selectable in 2°C and 10°C / 4°C and 10°C.

Table 11 SNT-6A package

Setting pin		Hysteresis temperature (°C)
HYS1	HYS2	
"H"	"H"	2
"H"	"L"	4
"L"	"H"	10
"L"	"L"	0

Table 12 SOT-23-5 package

(1) Hysteresis option = A

Setting pin	Hysteresis temperature (°C)
HYS1	
"H"	2
"L"	10

(2) Hysteresis option = B

Setting pin	Hysteresis temperature (°C)
HYS1	
"H"	4
"L"	10

[Delay circuit]

In order to prevent error, S-5841 Series has noise suppression time (t_{delay}). The followings are about the action when DET output is in active high.

If the temperature is lower than the detection temperature ($+T_D$), the DET pin is in low level. Although the output from the comparator goes in active due to noise, if the period in which this status continues is shorter than noise suppression time, the DET pin keeps its setting low level. After that, the output from the comparator goes in active because the temperature rises and exceeds the detection temperature, so that the period exceeds more than noise suppression time, the DET pin is set in high level.

■ Application Circuit

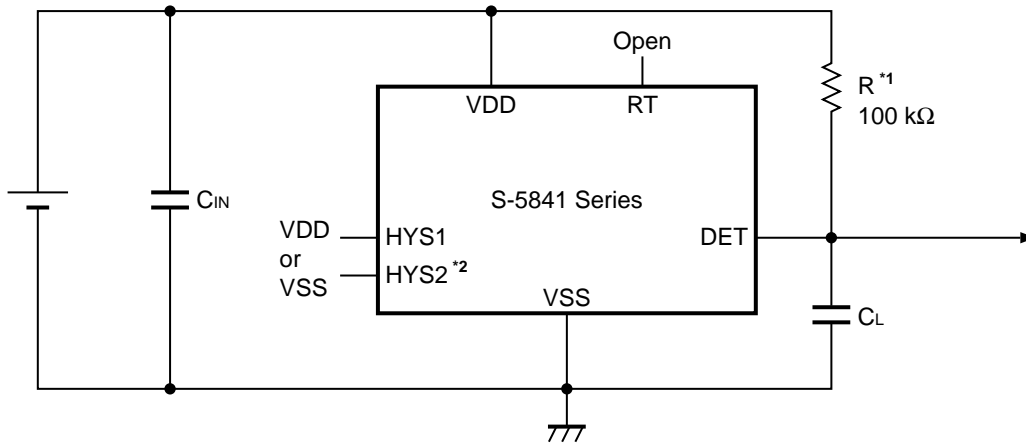

- *1. Resistor is unnecessary for the CMOS output product.
- *2. The HYS2 pin is not equipped for the S-5841 with SOT-23-5.

Figure 9 Application circuit

Caution The above connection diagram will not guarantee successful operation. Perform thorough evaluation using actual application to set the constant.

■ Precautions

- Set a capacitor (C_{IN}) of about 0.1 μF between the VDD and VSS pin for stabilization.
- Set a capacitor (C_L) of about 1 μF for the DET pin to prevent malfunction caused by the noise when the power supply is applied.
- The IC may oscillate by setting a capacitor to the RT pin. Set the RT pin open in use.
- If the RT pin is short-circuited to VSS, the DET pin becomes active in this IC.
- Fix the HYS1 pin and the HYS2 pin VDD or VSS in use.
- Do not apply an electrostatic discharge to this IC that exceeds the performance ratings of the built-in electrostatic protection circuit.
- SII claims no responsibility for any disputes arising out of or in connection with any infringement by products, including this IC, of patents owned by a third party.

■ Characteristics (Typical Data)

1. Current consumption vs. Power supply voltage characteristics

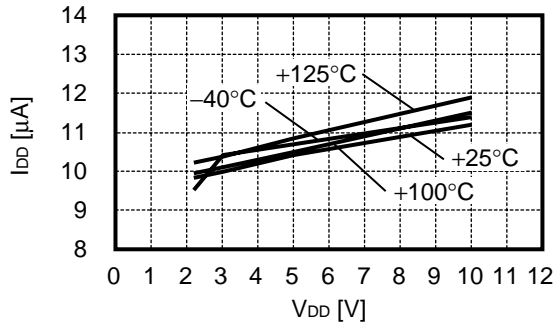

2. DET pin current "H" vs. Power supply voltage characteristics (CMOS output product only)

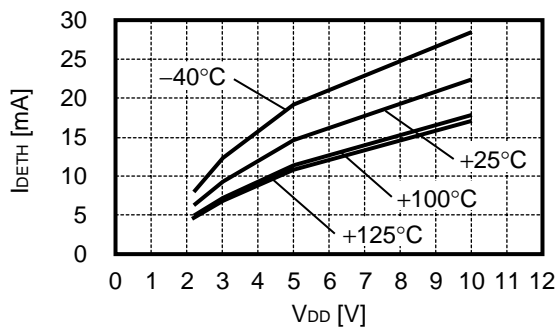

3. DET pin current "L" vs. Power supply voltage characteristics

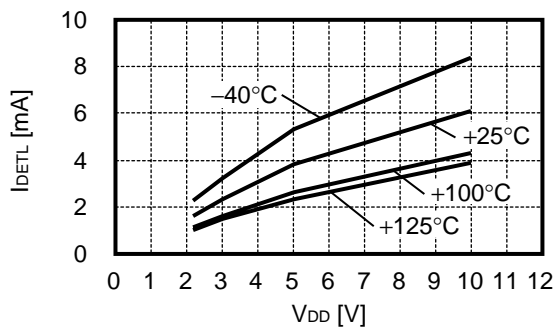

4. Noise suppression time (t_{delay}) vs. Power supply voltage characteristics

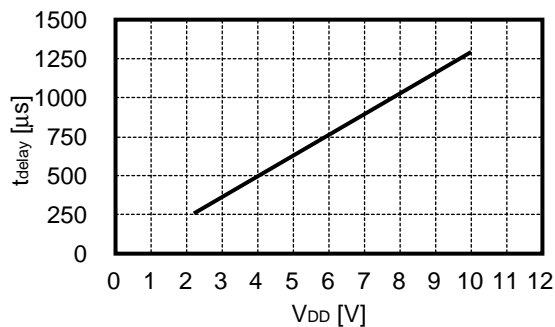

5. Response against heat Output voltage (V_{DET}) vs. Time (t)

(1) When packages are put into the air of +100 degrees from the air of +25 degrees at $t = 0$ s

$V_{DD} = 3.0$ V, $C_L = 0$ μ F, Detection temperature = +70°C, Active low

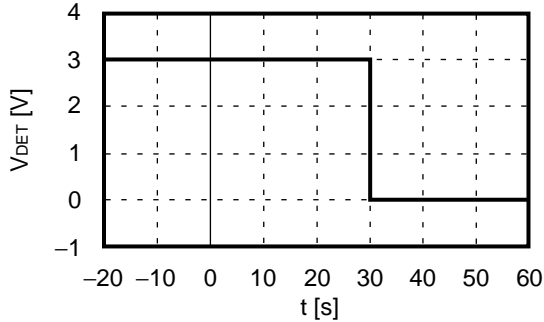

(2) When packages are put into the liquid of +100 degrees from the air of +25 degrees at $t = 0$ s

$V_{DD} = 3.0$ V, $C_L = 0$ μ F, Detection temperature = +70°C, Active low

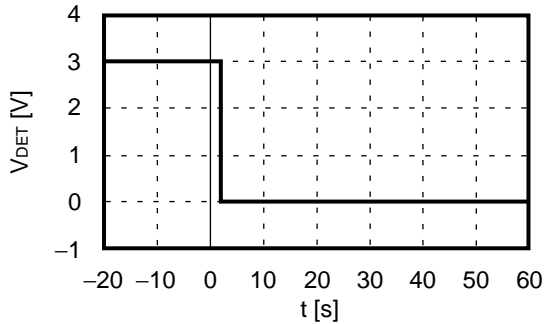

6. Response against startup

(1) The detection temperature or lower ($T \leq +T_D$)

$C_L = 0$ μ F, Active low

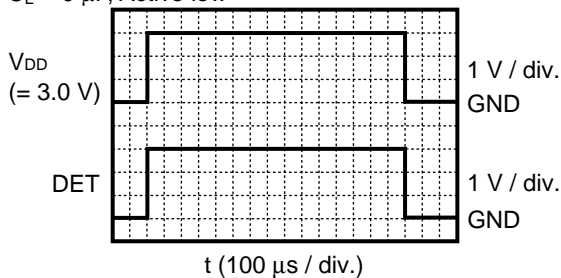

(2) Higher than the detection temperature ($T > +T_D$)

$C_L = 0$ μ F, Active low

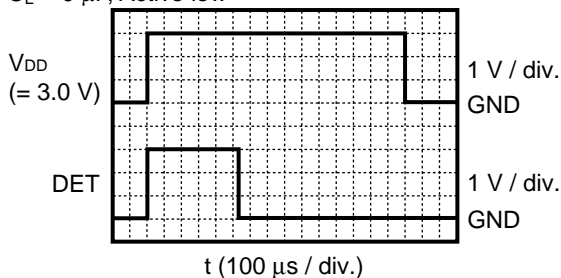

■ Marking Specifications

1. SNT-6A

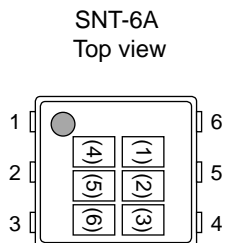

(1) to (3) : Product code (refer to **Product name vs. Product code**)
(4) to (6) : Lot number

Product name vs. Product code

Product Name	Product Code		
	(1)	(2)	(3)
S-5841A70A-I6T1x	T	I	G
S-5841A80A-I6T1x	T	I	H
S-5841A90A-I6T1x	T	I	I
S-5841A50D-I6T1x	T	H	A

Remark1. Please contact our sales office for the products other than those specified above.

- 2. x: G or U
- 3. Please select products of environmental code = U for Sn 100%, halogen-free products.

2. SOT-23-5

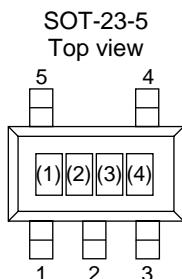

(1) to (3) : Product code (refer to **Product name vs. Product code**)
(4) : Lot number

Product name vs. Product code

Product name	Product Code		
	(1)	(2)	(3)
S-5841A55D-M5T1x	T	H	B
S-5841A65D-M5T1x	T	H	C
S-5841A75D-M5T1x	T	H	D
S-5841A85D-M5T1x	T	H	E
S-5841A95D-M5T1x	T	H	F

Remark1. Please contact our sales office for the products other than those specified above.

- 2. x: G or U
- 3. Please select products of environmental code = U for Sn 100%, halogen-free products.

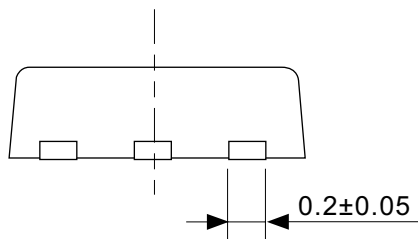
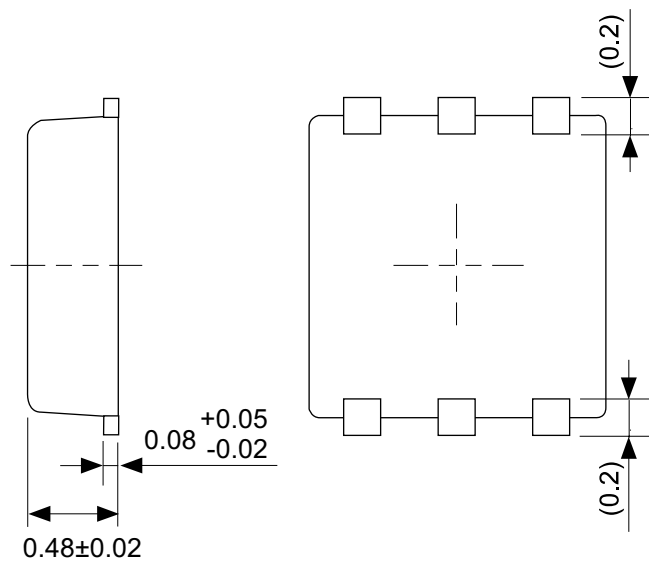
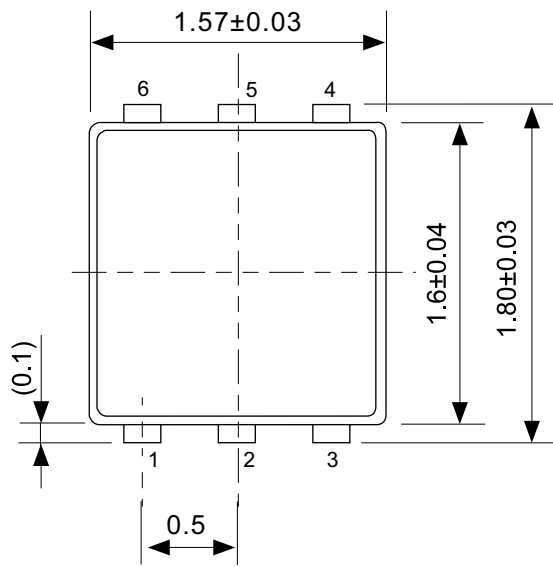

No. PG006-A-P-SD-2.0

TITLE	SNT-6A-A-PKG Dimensions
No.	PG006-A-P-SD-2.0
SCALE	
UNIT	mm
Seiko Instruments Inc.	

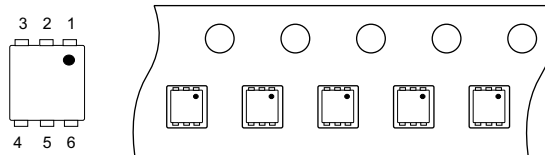
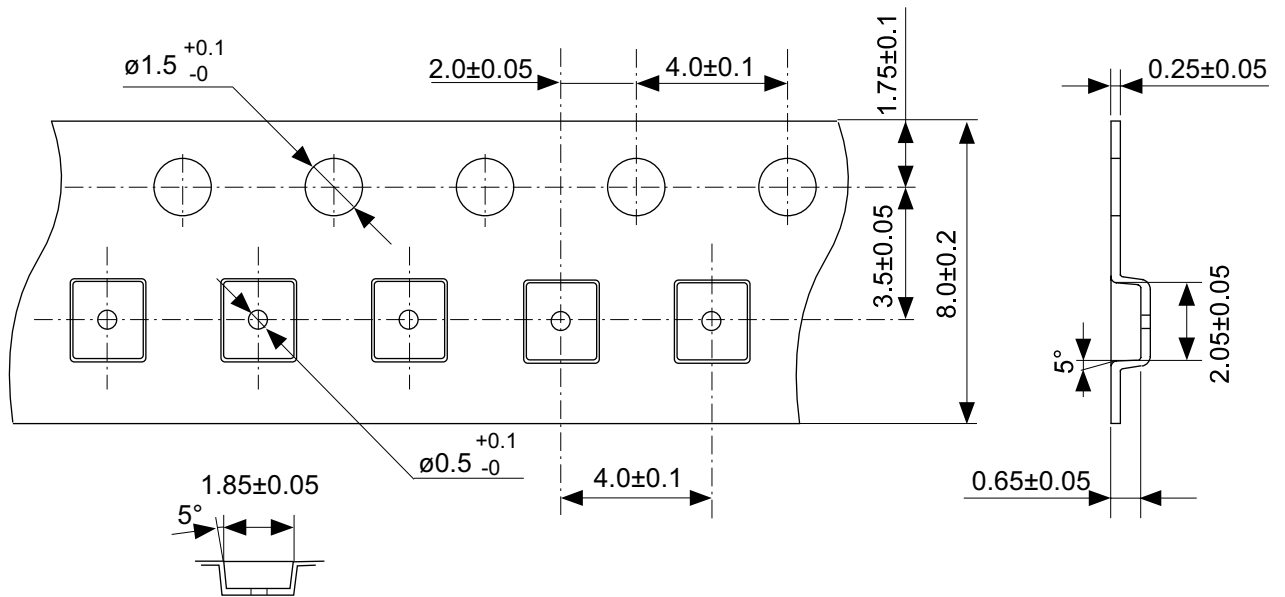

Feed direction →

No. PG006-A-C-SD-1.0

TITLE	SNT-6A-A-Carrier Tape
No.	PG006-A-C-SD-1.0
SCALE	
UNIT	mm
Seiko Instruments Inc.	

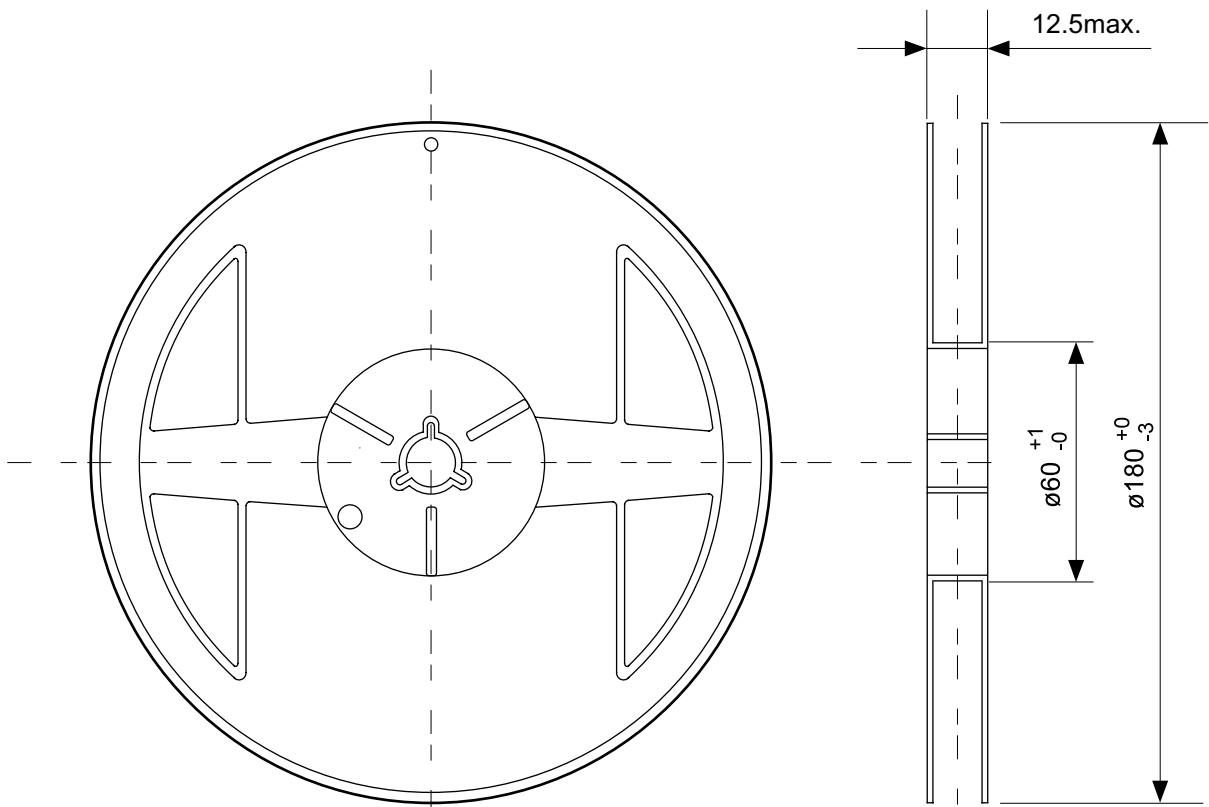

Enlarged drawing in the central part

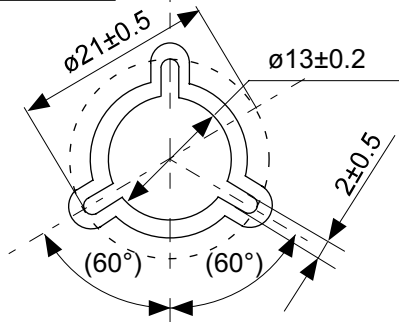

No. PG006-A-R-SD-1.0

TITLE	SNT-6A-A-Reel		
No.	PG006-A-R-SD-1.0		
SCALE		QTY.	5,000
UNIT	mm		
Seiko Instruments Inc.			

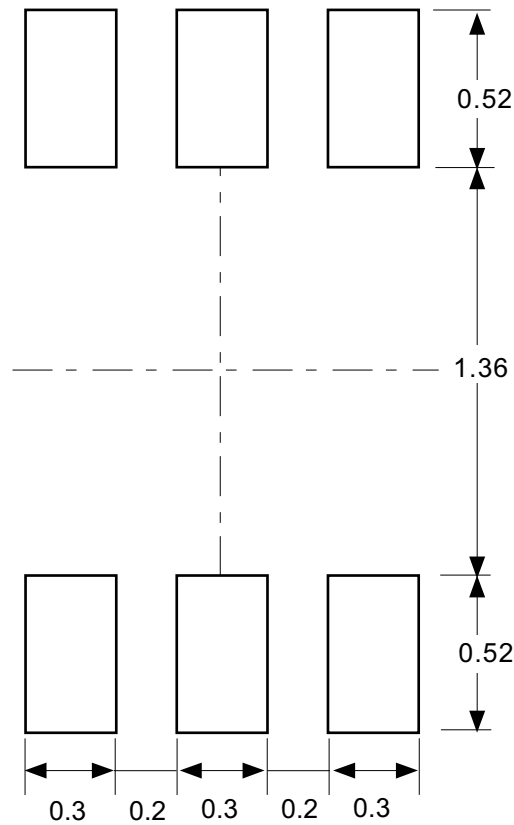

Caution Making the wire pattern under the package is possible. However, note that the package may be upraised due to the thickness made by the silk screen printing and of a solder resist on the pattern because this package does not have the standoff.

注意 パッケージ下への配線パターン形成は可能ですが、本パッケージはスタンドオフが無いので、パターン上のレジスト厚み、シルク印刷の厚みによってパッケージが持ち上がる場合がありますのでご配慮ください。

No. PG006-A-L-SD-3.0

TITLE	SNT-6A-A-Land Recommendation
No.	PG006-A-L-SD-3.0
SCALE	
UNIT	mm
Seiko Instruments Inc.	

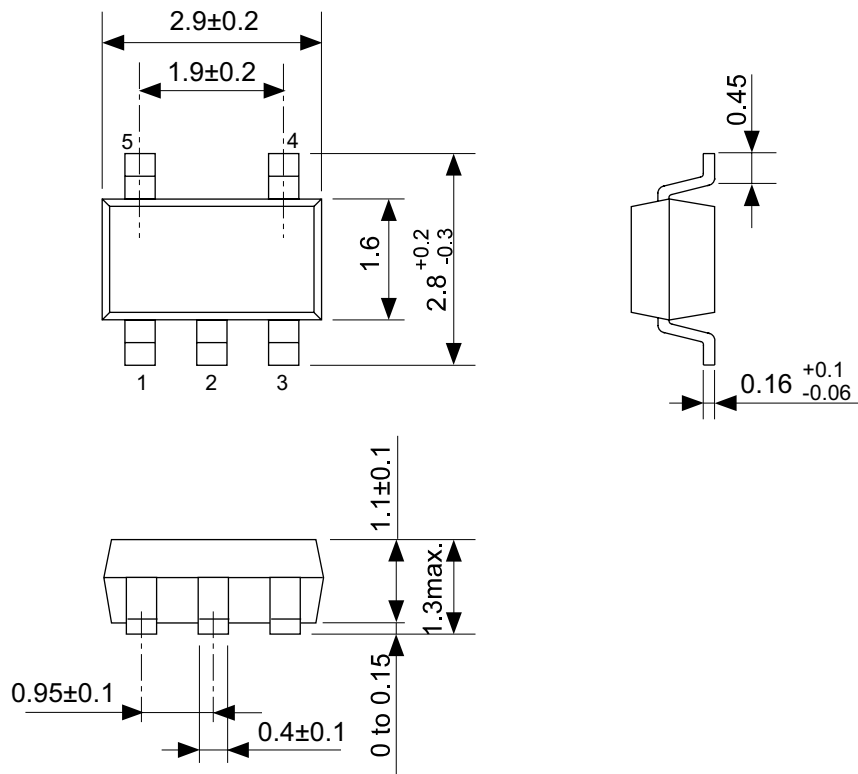

No. MP005-A-P-SD-1.2

TITLE	SOT235-A-PKG Dimensions
No.	MP005-A-P-SD-1.2
SCALE	
UNIT	mm
Seiko Instruments Inc.	

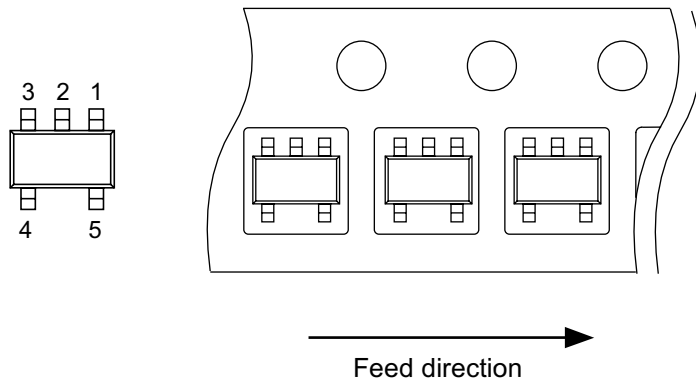
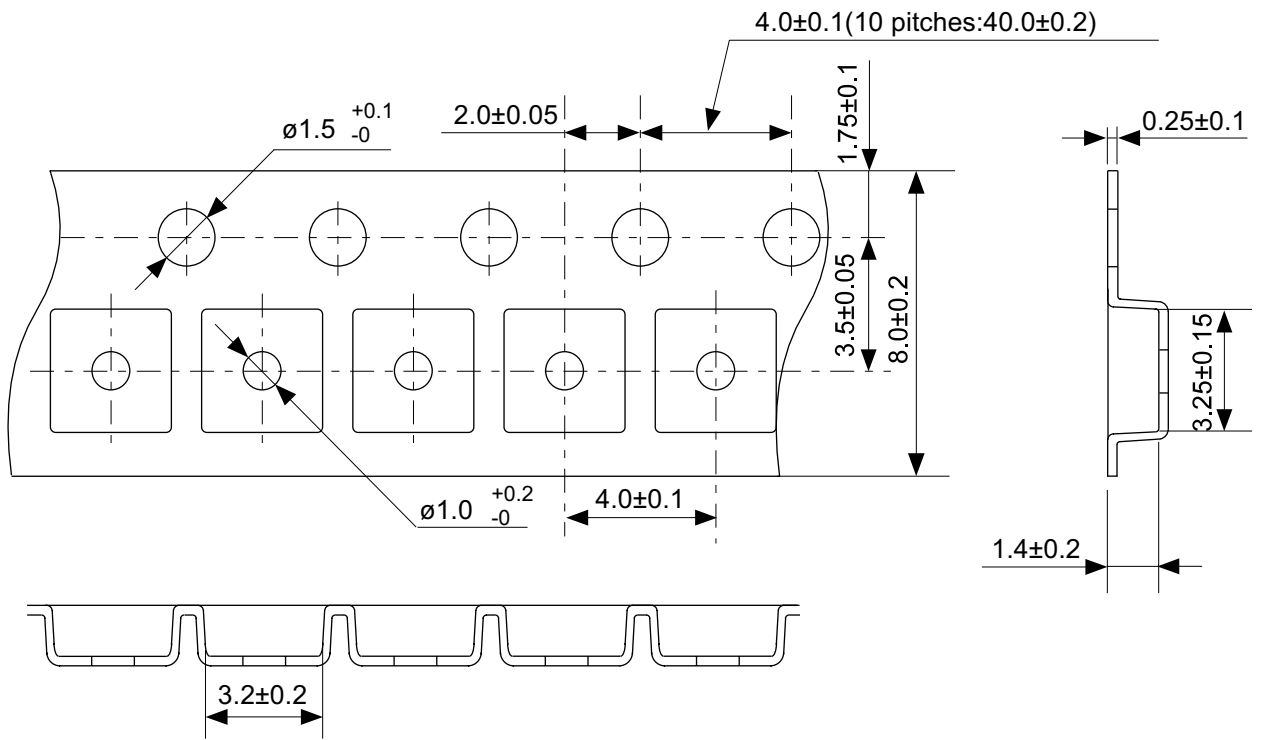

No. MP005-A-C-SD-2.1

TITLE	SOT235-A-Carrier Tape
No.	MP005-A-C-SD-2.1
SCALE	
UNIT	mm
Seiko Instruments Inc.	

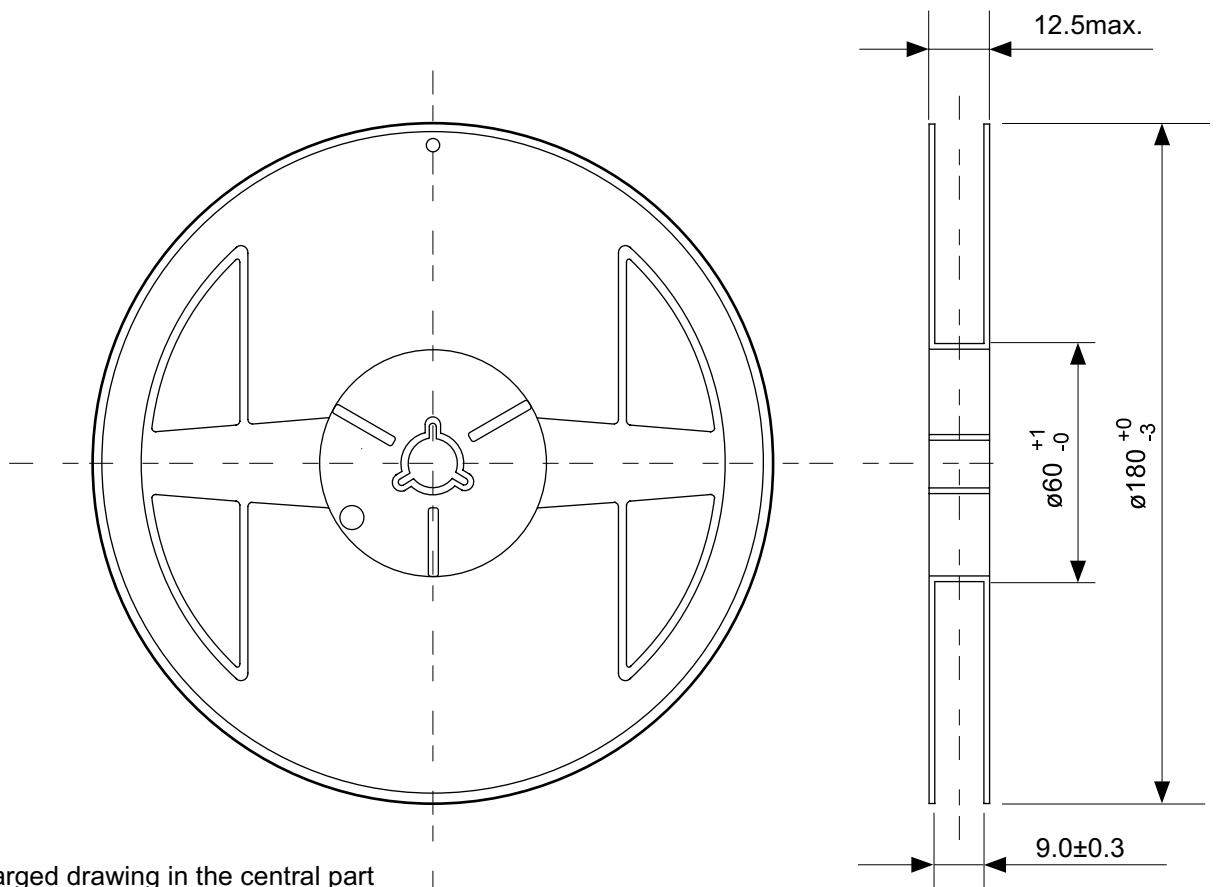

Enlarged drawing in the central part

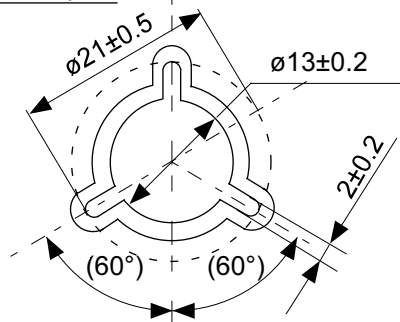

No. MP005-A-R-SD-1.1

TITLE	SOT235-A-Reel		
No.	MP005-A-R-SD-1.1		
SCALE		QTY.	3,000
UNIT	mm		
Seiko Instruments Inc.			



Seiko Instruments Inc.
www.sii-ic.com

- The information described herein is subject to change without notice.
- Seiko Instruments Inc. is not responsible for any problems caused by circuits or diagrams described herein whose related industrial properties, patents, or other rights belong to third parties. The application circuit examples explain typical applications of the products, and do not guarantee the success of any specific mass-production design.
- When the products described herein are regulated products subject to the Wassenaar Arrangement or other agreements, they may not be exported without authorization from the appropriate governmental authority.
- Use of the information described herein for other purposes and/or reproduction or copying without the express permission of Seiko Instruments Inc. is strictly prohibited.
- The products described herein cannot be used as part of any device or equipment affecting the human body, such as exercise equipment, medical equipment, security systems, gas equipment, or any apparatus installed in airplanes and other vehicles, without prior written permission of Seiko Instruments Inc.
- Although Seiko Instruments Inc. exerts the greatest possible effort to ensure high quality and reliability, the failure or malfunction of semiconductor products may occur. The user of these products should therefore give thorough consideration to safety design, including redundancy, fire-prevention measures, and malfunction prevention, to prevent any accidents, fires, or community damage that may ensue.